



Study of Heritage
Led Actions for
Renewal &
Regeneration

RAMELTON ACTION PLAN

Dedalus Architecture •
Bath Terrace, Main Street,
Moville, Co. Donegal

— July 2020 —





Contents

Introduction	3
Background & Policy Context	4
About this Plan – Study Area: Four Neighbourhoods	5
The Mall & Quays	6
Castle Street & Back Lane	9
Church Street & Chapel Road.....	12
Bridge End & The Green	15
Survey Findings	18
Health Check	24
Consultation	26

Ramelton: An Overall Vision	27
Proposed Actions	28
Action 1: Repair of Historic Buildings & Streets	29
Action 2: Public Spaces for People	32
Action 3: Commercial Activity	37
Action 4: Historic Town Centre.....	38
Action 5: Environmental Action.....	39
Action 6: Pedestrian & Cycling Links	40
Bibliography.....	41
Appendix.....	42



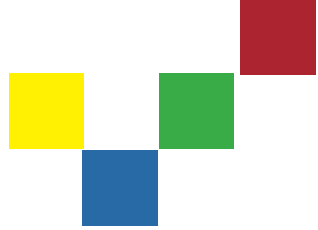

Introduction

The Ramelton Action Plan will support the renewal and regeneration of the town through a number of actions that are designed to fulfil its potential and enhance its historic environment. The actions set out in this plan aim to protect Ramelton’s character as a designated Heritage Town and utilise its unique townscape with a view to making it a better place to live in and to visit. The Ramelton Action Plan is one of the outputs of the Town and Village Renewal funding awarded to Donegal County Council by the Department of Rural & Community Development in late 2016.

This Plan will ensure that Ramelton is in a position to avail of future funding and investment opportunities as they arise and will support the local community and business sector, in partnership with Donegal County Council, to enable the regeneration and provision of sustainable and sensitive development within the town. The Plan



defines a vision for the town’s future and comprises a range of ideas, actions and projects that may be implemented to achieve that vision.

It is envisaged that the actions and improvement projects identified in the Plan will:

- Ensure the reuse, restoration and appropriate adaptation of the town’s distinctive built fabric on the basis of an informed ‘heritage led’ approach;
- Facilitate public realm improvements to enhance the function of public spaces for use by people;
- Encourage new economic activity by extending the designated town centre eastwards to its original historic core;
- Re-establish the historic town centre as a living place;
- Support an environmentally informed approach to the regeneration of the town; and
- Improve cycling & pedestrian linkages and extend existing walking & cycling routes throughout the town.

Methodology

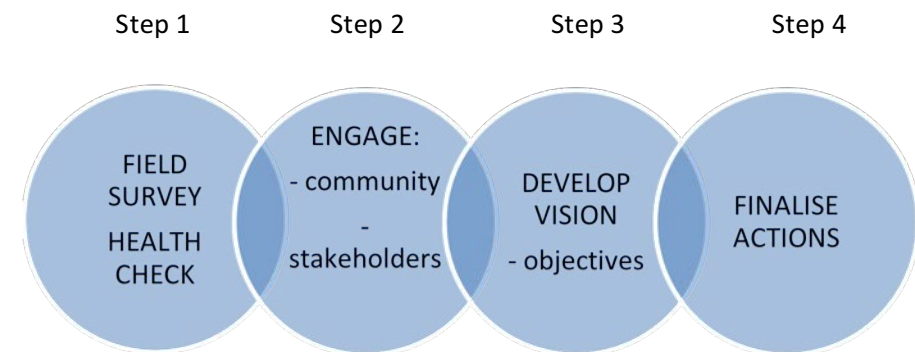

Background & Policy Context

Under its designation in the Donegal County Development Plan, as a 'Layer 2B Strategic Town with Special Economic Function', the function of Ramelton is to drive growth and development in the County. Ramelton is positioned to take advantage of its significant built heritage resources and is also designated as a 'heritage town'. The historic town core has a zone of archaeological potential and many of its most important historic buildings are either listed in the Record of Protected Structures or the National Inventory of Architectural Heritage. As a heritage town the objectives and policies of the County Development Plan recognise the continuing evolving and important role this designation has in promoting economic development, especially in relation to tourism. The protection of the special character of the town is reliant both on sensitive future development that is informed by the historical setting and careful maintenance and conservation of its historic buildings and public spaces.

Ramelton is a town of significant built, social and cultural heritage with a unique regional character and comparable in quality to the most visited historic places in Ireland. The current town was founded as a plantation settlement, in the early 1600s, on the site of an O'Donnell Castle by William Stewart of Ayrshire. It was an important port located at a point where the River Lennon flows into Lough Swilly and became a prosperous centre for industry, trade and local government. Its former wealth is reflected in the quality of its architecture and is characterised by elegant functional buildings including classically inspired vernacular warehouses along the quayside and the former Guild Hall on Castle Street which was the seat of the Grand Jury.

The increasing trade in linen for the export market was reflected in the building of impressive town houses in the late eighteenth century; during which time, the port expanded and the town grew westward along the river.

On the north side of the river, Bridge End was developed around the large mill sites and bleaching green which is County Donegal's largest surviving industrial heritage site associated with the linen trade. There was a decline in the linen industry in the 1840s due to competition from Belfast. In the 1850s, the silting of the port and the arrival of the railway in Letterkenny contributed to the decline in industry in Ramelton. Its role as a centre for local government ended with the abolition of the Grand Jury system in 1898. At the beginning of the twentieth century, Ramelton had seven churches and was known as 'The Holy City' due to the religious diversity found in the town. The town retained its importance as a rural business and market centre into the twentieth century.



About this Plan – Study Area: Four Neighbourhoods

Dedalus Architecture, on behalf of Donegal County Council, undertook a comprehensive survey of the current condition of buildings in the town, completed a detailed ‘health check’ of occupancy and commercial activity in the town centre and carried out consultative workshops with the local community and local stakeholders.

Thus informed by community input and local knowledge, and guided by a comprehensive survey of more than 400 buildings the Action Plan has identified areas most in need of intervention; and proposes a number of positive actions to address current incidence of dereliction to assist in the task of maintaining, repairing & restoring existing buildings; informing proposals for new buildings, for development within the gaps in the town fabric, for public realm improvements & for the appropriate adaptation & reuse of the town’s built heritage.

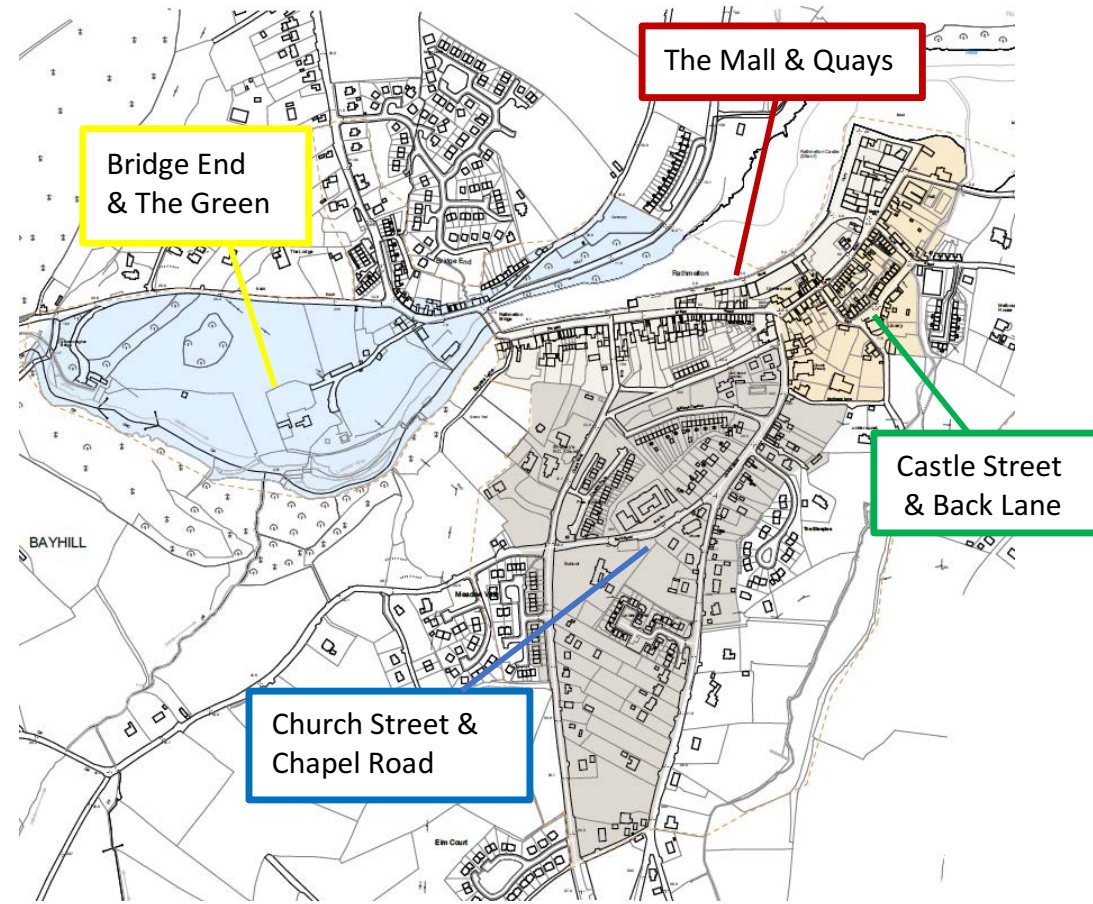

Study Area

The study initially identified four distinct neighbourhoods, described in the following pages, and highlighted in the map above. These character areas reflect the historical extents of the town and its landscape setting. The nature of each area has had a direct bearing on its historical development. The study findings are organised to better understand the heritage resources that are present in the four neighbourhoods.

The Mall & Quays



The Mall & Quays

A popular name for a fashionable walking route in the 18th century, “The Mall” provides a riverside pathway which currently runs on the south side of the river from the Bridge to Gamble’s Square. Further east, are commercial buildings, warehouses and neglected sites, which together once formed the historic commercial centre of the town, much of which served the linen industry. These activities and agricultural markets have gradually disappeared so that the current commercial centre is only a fraction of its original footprint and large parts of the town are barely used at all.

Postcards and drawings and numerous photographs from the 19th century demonstrate the value of the landscape setting of the town; most of which can be appreciated from this neighbourhood.

The Mall initially contained a mix of houses and associated commercial buildings to the rear, although the latter gradually declined as the town has become more residential in character. Commercial activities, most often associated with agriculture, continued to the east end of the Mall. Ramelton Quay was the threshold to export, and international trade, which generated the most significant part of the wealth of the town.

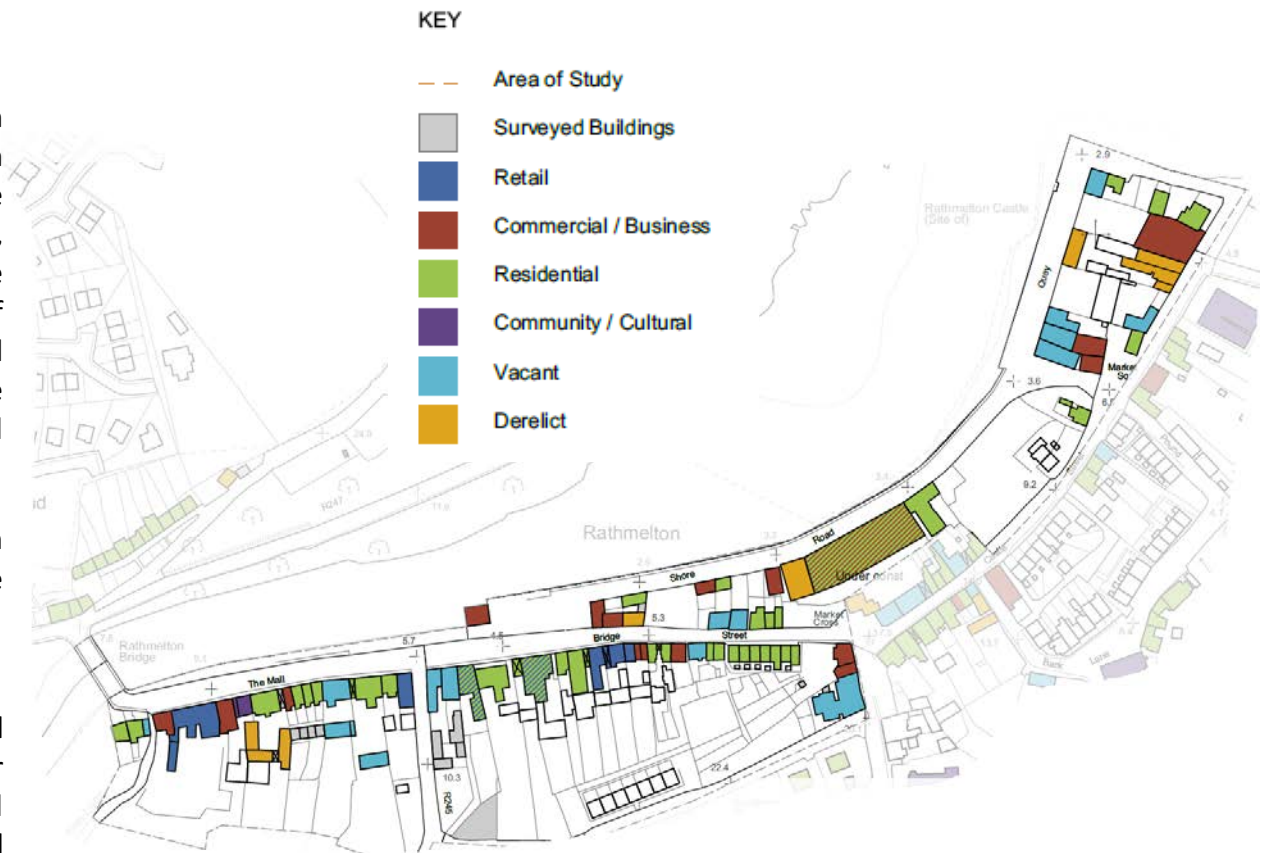

Abandoned warehousing, the former market place and merchant houses coexist here today. Although by now the quay is hardly used for its original purpose, there is still potential to do so both for leisure or updated commercial purposes.

This is the part of the study area with the oldest buildings laid out in the 17th century between the former O'Donnell Castle at the quayside, market cross, and the post medieval parish church. The area also contains the best quality Georgian period town houses and warehouses. There are many high quality buildings in this area that would benefit from repair & renewal. There are also several notable buildings which show what can be achieved when a conservation approach to repair is taken. In order to facilitate the regeneration of this area, public infrastructure is needed to manage basic needs such as transport, refuse storage, car pooling and other facilities that will make town centre living affordable and desirable in future years.

In addition to individual buildings, Gamble's Square, the former Quayside, Market Cross & former Pig market once formed important urban spaces in the life of the town, and are all now abandoned with the result that the commercial core of the town has moved westwards around the road passing through the town.

The restoration of these spaces for public use has potential to re-establish the town centre as a living place in which to spend time, entertain and undertake day to day transactions. Gap sites, abandoned public green space and verges all have potential to serve the community in the transition, needed today, to a future low carbon economy tomorrow.



An aerial photograph of a residential street, likely in a rural or semi-rural area. The street is lined with two-story houses, some painted in light blue and others in white. The houses have dark roofs and are surrounded by greenery, including trees and bushes. In the background, there are rolling green hills under a blue sky with scattered white clouds. A large green triangle is overlaid on the left side of the image, containing the text 'Castle Street & Back Lane'.

Castle Street & Back Lane

Castle Street & Back Lane

Immediately to the south of the Quayside, this is the former administrative centre of the town formed by the south side of Castle Street, Mortimer's Lane & Back Lane. Characterised by two Presbyterian churches, including the oldest in Ireland, there is also a Masonic lodge and manse. There are also groups of modern town houses and a former mill building; these were affected by significant flooding in 2014.

The buildings here mostly date from the Georgian period although several are older as this area formed part of the 17th century core of the town. Houses on Castle Street are of particular historic interest, although many have now become quite run down and several, in focal locations have become derelict.

At the eastern end of the street, the sites of a number of single storey thatched houses were redeveloped in the 20th century so that whilst some of the historical character has been lost the enclosure of the street on the southern side is still largely intact, although its urban character has been lost to a left-over grassed area on the north side.

There is an abandoned building project at the western end of the street dating from the last financial crisis, casting a shadow over the remains of the Market Cross, once the most important commercial space in the town.

The most important vacant building is the former Presbyterian meeting house, last used as the public library. Thought to be the oldest Presbyterian church building in Ireland, the building contains old ship timbers and is categorised as an archaeological monument.

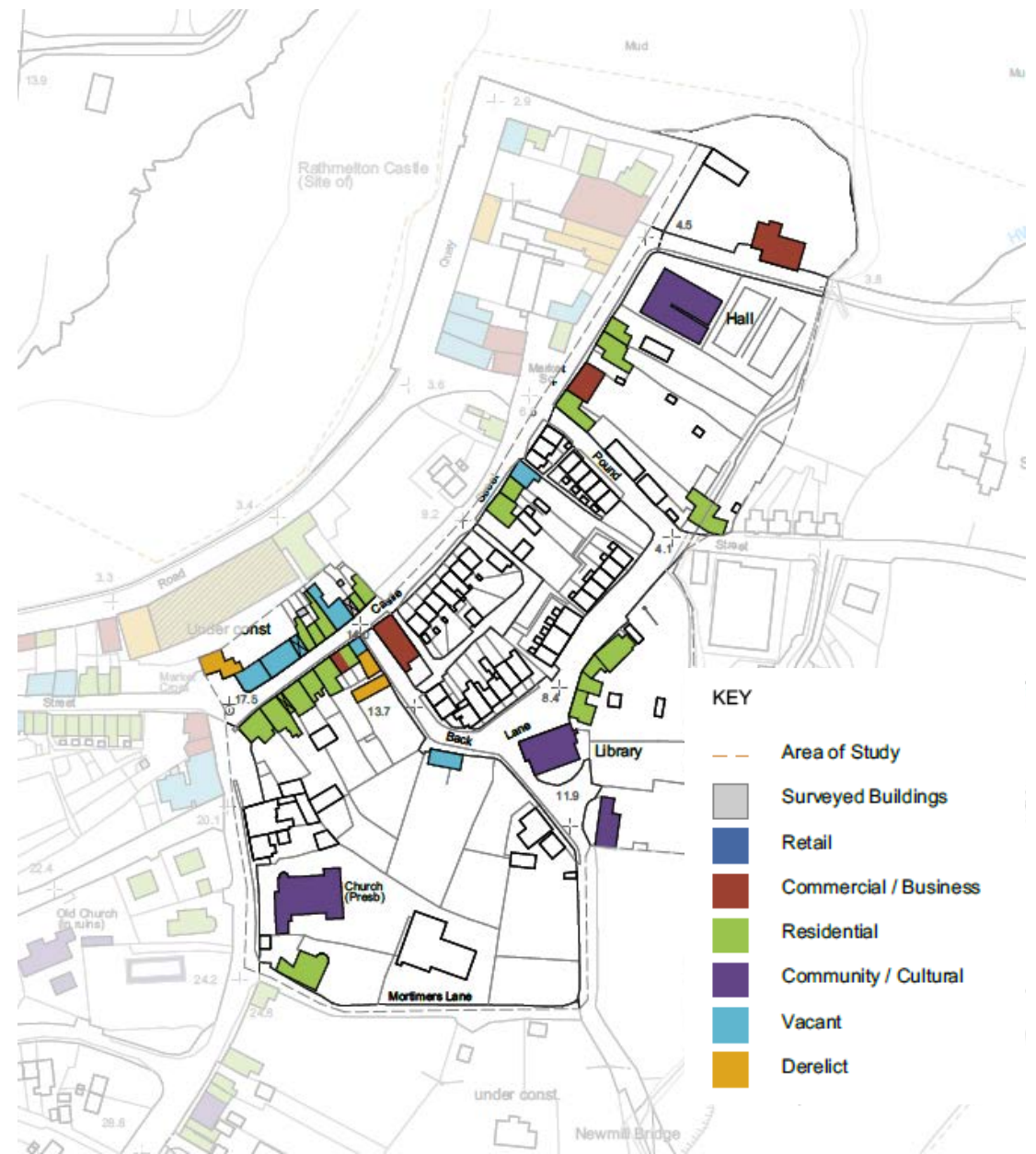

There are several vacant sites within this neighbourhood; some of these have been utilised by the community to provide informal garden spaces providing some visual amenity. Painted window covers have been used to provide temporary relief to the appearance of some abandoned buildings, although these conceal the increasingly derelict state of the structures behind.

Reoccupation of this core area would be encouraged by reinstatement of the social function of the urban spaces which serve it and provision of communal facilities that are not currently available to individual residents.

There is potential to restore the historic streetscape using appropriate materials for new development and by taking actions to reuse empty buildings.

An essential element in planning for the renewal of this area will be ensuring that the town centre remains an attractive place to both live and work.

The visual appearance and safety of the street requires that buildings are kept in a good state of repair, particularly those prominent historical buildings which give Ramelton its unique identity and character. A number of important buildings which have fallen into disrepair currently provide an exciting opportunity for their creative reuse. The actions recommended in this plan are also intended to provide support and incentivise renewal of properties that are privately owned.



Church Street
& Chapel Road



Church Street & Chapel Road

The area to the south of the commercial core is taken up by churches and housing. The Churches and associated land take up the greatest land mass in this area. In the past, the space offered allowed for development and expansion of schools, hospital and other social and institutional establishments.

This area also contained public water infrastructure serving the rear of the Mall and town centre.

The area, more recently, has seen intensification of traffic by-passing the centre of the town. With the exception of local authority houses clustered adjacent to the rear of the Mall, the buildings are quite dispersed, providing space for large trees and gardens giving the area a suburban character.

The streets in this area, unlike other parts of Ramelton, were developed in the 19th century and infill space between Grand Jury roads which connected the town with the houses of the important land owners outside the town.

The Church of Ireland was designed to form the focal point of the view from the driveway of the Rectory at Aghnagaddy Glebe, to the south of the town. Whilst the church tower is quite small, none of the several other churches in the “Holy City” of Ramelton challenged the primacy of this structure in the town setting.



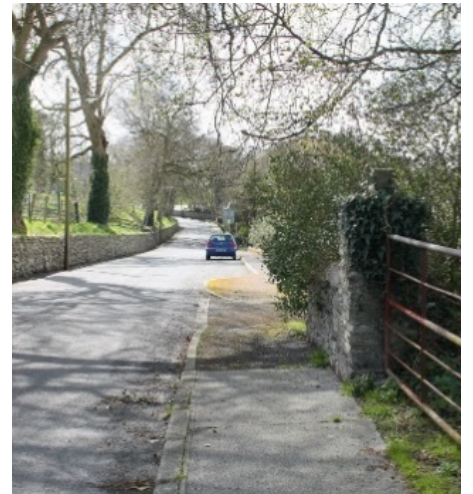
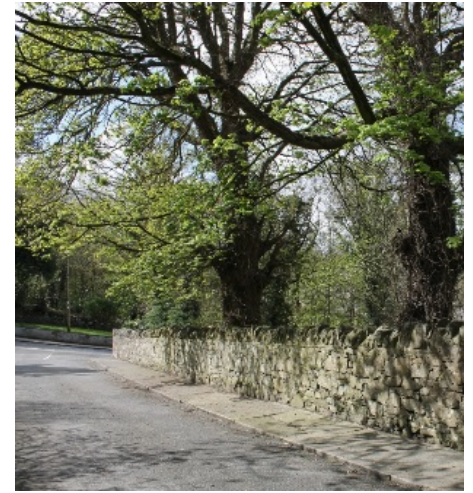

Bridge End
& The Green



KEY

- Area of Study
- Surveyed Buildings
- Retail
- Commercial / Business
- Residential
- Community / Cultural
- Vacant
- Derelict



Bridge End & The Green

The buildings and settlement on the northern side of the Leannan, are mostly closely associated with the manufacture and bleaching of linen in 18th century and is the best-preserved industrial landscape in county Donegal. The picturesque appearance today conceals the industrial heritage past of this part of the town centre, which also had a large flour mill; a tannery, and weaving mill close to the bridge. The 'Green' beyond was used for laying out finished linen articles watched over by

two warden's huts, also still present. This area is integral to the history and settlement of Ramelton, but does not form part of the designated town centre area.

The Action Plan, however, includes this area which is integral to the industrial development of the town and, in conjunction with local agriculture, is the source of its historical wealth.

The remains of the linen weaving, bleaching, flour mill, fishery and kelp processing industries have potential to form elements of a dedicated industrial heritage trail. The historical buildings and their attendant grounds also currently form the setting for an established footpath used by local people linking the town centre, Green Lane, Drummonaghan Weir and bridge, with woodland lining the south side of the river.

There is potential for a looped series of walks that might also be extended westwards to Carnisk and onto the former Ramelton Water Works site, also of industrial heritage significance.



Survey Findings



Survey Findings – Buildings at Risk

The health check has identified thirteen buildings in the town that are derelict, which is approximately 7% of the overall building stock surveyed. A further twenty five buildings, or 13% of the building stock was identified as being vacant. A large proportion of the vacant buildings also required maintenance which, with the absence of regular use, may also become derelict within a short space of time.

Whilst actions are already being taken to reuse some of the vacant buildings, approximately 20% of the building stock is currently unused, a high proportion of these are either protected structures, or of some architectural value. These are also the same buildings which have made Ramelton well-known throughout Ireland and it would not be alarmist to determine that the very character and significance of the town is under threat if this situation is not addressed.

Finding appropriate sustainable new uses for the historic buildings and sites must be a priority for any new development.

Approximately 20 buildings have been identified as being ‘at risk’; these have been prioritised on the basis of their condition. Actions proposed to address this are proposed on a prioritised basis.

Specialist assistance is needed in repairing protected buildings, and there are only limited incentives to owners to make the necessary investment in these structures. Other incentives that consider the embodied energy contained within historic buildings when measuring the sustainability of development must also be promoted in the future. Intervention is needed in the immediate term to prevent further loss.



Survey Findings – Vacant Sites & Pocket Parks

The relatively large number of derelict buildings and sites present a major challenge to repairing the town of Ramelton. Individual buildings in private ownership require action by owners or the local authority.

Elsewhere, the sites of buildings demolished in the past have been grassed over. Whilst providing an initial visual improvement green leftover space has little ecological value and, if unused, creates a permanent hole in the fabric of the town. The site of the former pig market at the eastern end of the town has been identified as an area which has some amenity value but also effectively separates the Quayside and former market area from the remainder of the town and where changes to its current use and design may also have the potential to rejoin these parts together.

Elsewhere, there are examples of left-over green spaces which have been appropriated by the community and the resulting changes have created spaces that are cared for, used by people and celebrate local connections and historical events. An action of the plan will be to facilitate local people in 'taking ownership' and the embellishment of left-over spaces and verges to create new pocket parks and 'guerilla gardens'.

These gardens would provide an opportunity for the creation of biodiversity and opportunities for people living within the town for growing flowers, food, fruit and vegetables.



Survey Findings – Public Spaces: The Market Cross

Ramelton is an historical “Market Town”; the presence of a market cross signified the right to hold a market granted by the monarch, or local barony. In Ireland, market crosses were often located in a space mid-way between church and castle, as is also the case at Ramelton.

Today, the space which once formed the very centre of the town, is completely given over to the circulation of cars which prevent any form of use by people. The market cross itself is also long gone, although there is now an opportunity, in conjunction with restoration of the adjacent buildings and vacant site to address this area to provide useful urban space that can be used by people to enhance their daily lives.



Survey Findings – Public Spaces: Gamble’s Square

The place currently named ‘Gamble’s Square’ is effectively used as a car park and also forms an unsafe junction where traffic from the Shore Road joins with traffic from Bridge Street. The naming of the square comes from a time when people would have enjoyed use of the space unchallenged by modern road traffic.

Market stalls and casual traders use this area, but have secondary status to vehicles, and are located along the riverside verge impeding use of the footpath on this side.

There is an opportunity to recreate the civic space in front of Gamble’s shop once an old-fashioned emporium where it was possible to buy a length of cloth, or a boat ticket to America. Although now closed since 2012, Gamble’s has one of the best preserved shop fronts in Donegal. On the east side of this space there is a former wine bar, now a building at risk; on the west is the former fish market and alongside, the former market scales.

Reorganisation of this area has potential to provide a boost to market and shop traders by creation of an environment that people can spend time in and also provide an opportunity to extend the Mall footpath along the Shore Road to join with the Quayside.



Survey Findings – Public Spaces: Shore Road & the Quay

The Shore Road has relatively little road traffic. Despite this, there are only narrow footpaths on either side, giving vehicles a surplus of space. Whilst much of this area is useful for on-street parking, there is potential to reduce the road width to provide better spaces for pedestrians. This would be improved further by arranging traffic flows through the town so that vehicles were directed in one direction only.

The gravel footpath along the Mall is separated from much busier traffic by a low wall and sheltered by trees. There is potential for a gravel path, suitable for people to walk side by side, to extend along the Shore Road to join with the Quayside.

Changing traffic along this side to run in one direction would also provide space to improve provision for parking for cars and buses and to allow introduction of public vehicle charging points.

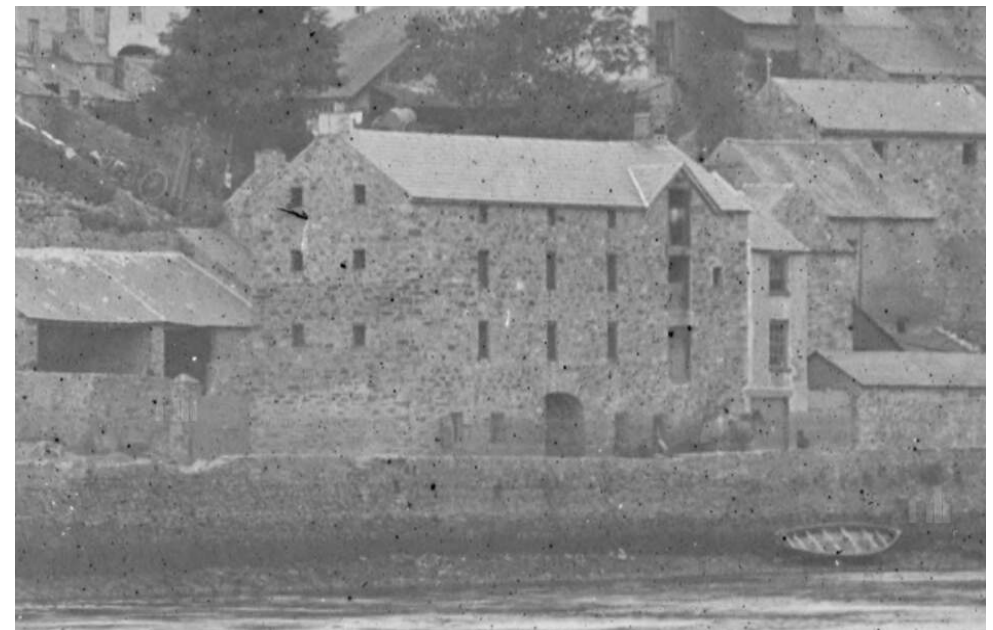

Health Check - Diversity of Uses: Overall Town Centre

The survey of current building usage demonstrates that Ramelton is primarily a residential town with a relatively small amount of commercial and retail space.

Vacant & derelict buildings account for approximately 20% of the overall building stock and, in combination, are the largest use class identified, other than residential.

The survey outcome has produced the statistics set out below. The survey mapping contained in the Appendix show the findings in relation to individual buildings:

Diversity of Uses Across the Town Centre

Retail	6	3%
Commercial	23.5	12%
Residential	111	58%
Community/ Cultural	13	7%
Vacant	25	13%
Derelict	13	7%

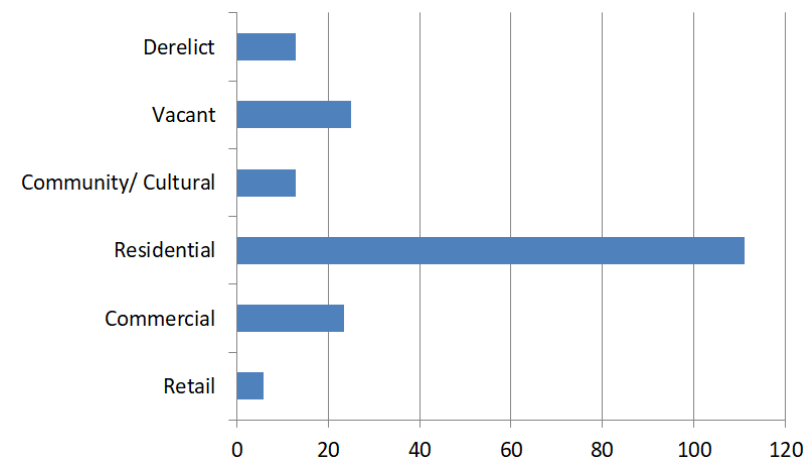
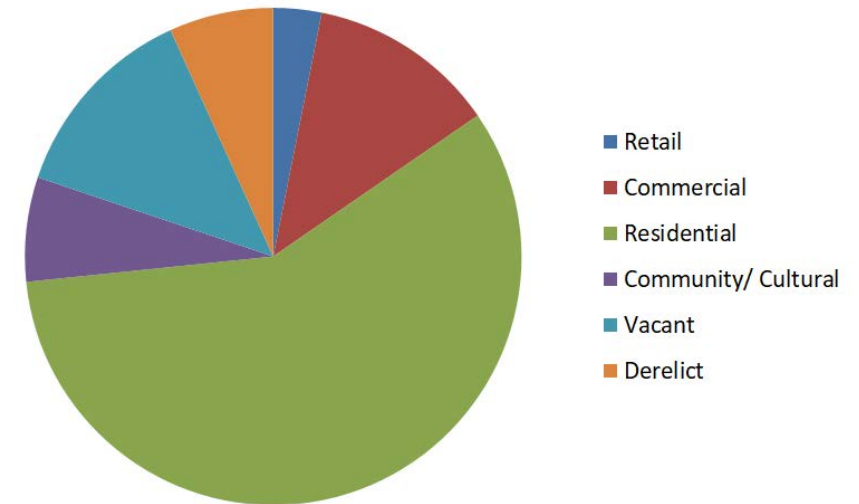

Health Check – Diversity of Uses: Neighbourhoods

1. The Mall and Quays		
Retail	6	7%
Commercial	16.5	20%
Residential	34.5	42%
Community/ Cultural	1	1%
Vacant	15	18%
Derelict	9	11%

2. Castle Street and Back Lane		
Retail	0	
Commercial	4	10%
Residential	22	56%
Community/ Cultural	4	10%
Vacant	6	15%
Derelict	3	8%

3. Church Street and Chapel Road		
Retail	0	
Commercial	0	
Residential	24	69%
Community/ Cultural	8	23%
Vacant	3	9%
Derelict	0	

4. Bridge End and The Green		
Retail	0	
Commercial	3.5	9%
Residential	30.5	85%
Community/ Cultural	0	
Vacant	1	3%
Derelict	1	3%

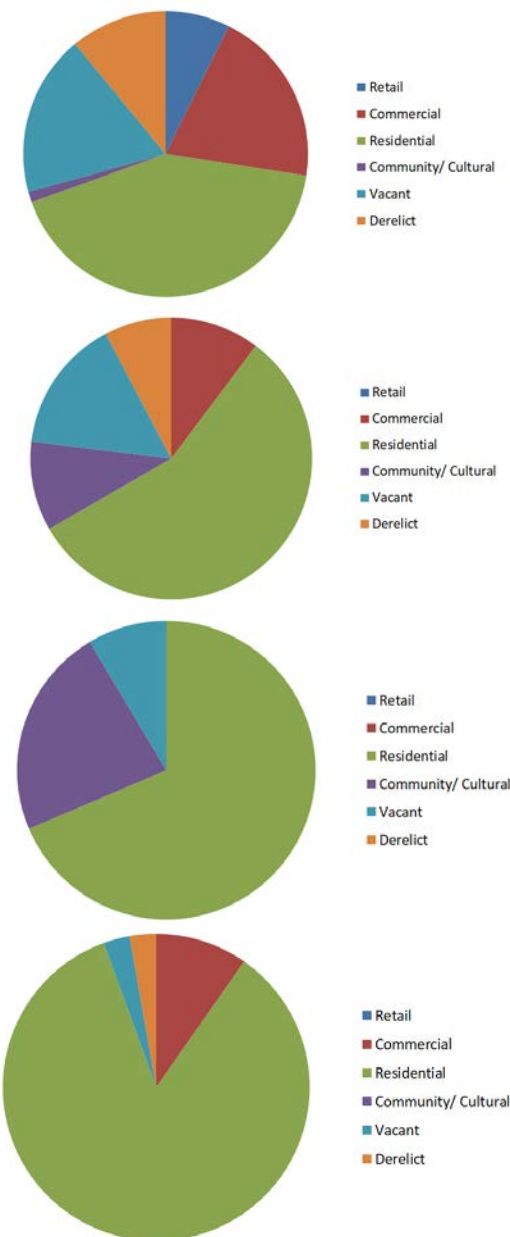

Consultation

A core objective of this plan is that the actions reflect the concerns of the local community and that implementation of the Actions that have been recommended will be developed by, and with the participation of, the local population and other key stakeholders with an interest in the future of Ramelton. The success of the plan is reliant in their involvement.

Consultation has taken place at a number of meetings & workshops and actions defined through informal dialogue over a period of nearly two years.

The Draft Ramelton Action Plan was made available for public viewing during the period 7th February 2020 to 13th March 2020. The consultation period and invitation to make written submissions were advertised via a local newspaper, through the Council's website, twitter and social media, and on Highland Radio. A public consultation event to facilitate the launch of the Plan to the public and allow for direct consultation with the general public in relation to the Plan was held on Wednesday 12th February 2020 at 7pm in Ramelton Town Hall.

A number of copies of the draft plans were available at the event and a submission sheet was also available to all attendees for receipt of submissions on the night, or prior to the end of the public display period. The event provided an opportunity for people to view the Draft Plan and to discuss it with members of Council staff. A Q&A session was facilitated following the presentation of the draft plan and a number of comments were made. Attendance at the event was considerable, with in excess of 100 people, all of whom actively participated with the Action Plan which is a strong indicator of both the interest in the project and the extent of engagement with the consultation process

In total 19 submissions from members of the public were received during the consultation period.



Ramelton – An Overall Vision

Through consultation with the local community and local stakeholders, a vision statement for the Action Plan has been developed to provide an agreed focal point for guiding action over the coming years to facilitate the achievement of this vision.

RAMELTON – A VISION

The heritage town of Ramelton is to fulfil its future potential through celebration of its past and the creation of a vibrant place in which to live & work. The unique character of the town, its historic buildings, public spaces, and gardens, and the care with which they have been repaired and put to creative new use, will be an attraction of interest to visitors, and a source of future prosperity, as it once again will be referred to as ‘Donegal’s Jewel’.

The objective for this Action Plan is to develop a coherent strategy to guide the renewal and regeneration of Ramelton with a particular focus on heritage, which has been identified as having the potential to result in strengthened tourism and business sectors, increased attractiveness to investors and also contribute to improving the general sense of well-being that people derive from investment in the future of their place.

Understanding the town’s existing heritage resources is essential in ensuring that it remains vibrant and contributes positively to the future of Ramelton.

The actions undertaken in the preparation of an Action Plan for the renewal and regeneration of Ramelton have been:

- To adopt a heritage-led approach to the renewal and regeneration of Ramelton in order to preserve the town’s distinct character.
- To encourage community participation and local engagement in the process of heritage-led regeneration of Ramelton.
- To consult with all relevant stakeholders in relation to the renewal and regeneration of Ramelton.
- To undertake a health check of Ramelton to record and understand the existing functionality, vibrancy and vitality of the town.
- To identify the issues and opportunities in relation to the renewal and regeneration of Ramelton.
- To identify and prioritise actions to contribute to the renewal and regeneration of Ramelton.

Ramelton – Proposed Actions

Through consultation with the local community a series of actions have been developed to realise the vision of this plan to provide for the future renewal and repair of the physical fabric of the town into a unique heritage asset. Ramelton will be an attractive and vibrant place that people want to live in, work in, and to visit. Ramelton will be increasingly identified as a destination town with a distinctive sense of place.

The Action Plan is designed to implement the objectives of the community, namely to:

- Ensure the reuse, restoration and appropriate adaptation of the town’s distinctive built fabric on the basis of a ‘heritage led’ approach;
- Facilitate public realm improvements to enhance the function of public spaces for use by people;
- Encourage new economic activity by extending the town centre eastwards to its original historic core;
- Re-establish the historic town centre as a living place;
- Support an environmentally informed approach to the regeneration of the town; and
- Improve cycling & pedestrian linkages and extend existing walking & cycling routes throughout the town.



Action 1 - Repair of Historic Buildings & Streets: Priority 1

A selection of buildings have been prioritised on the basis of their architectural significance, importance to the community, their current condition and the potential risk to local people. The town centre 'health check' has identified thirteen buildings in the town that are derelict and approximately 20 buildings have been identified as being 'at risk'; these have been prioritised for action on the basis of their condition and risk to the public.

With the exception of the large mill complex adjacent to The Green, all of the buildings are located in prominent positions, along the Mall & Quays, Castle Street & Back Lane.

The buildings are currently in a condition that they have become a challenge to their owners as well as the appearance of the historic town of Ramelton, which is designated as a heritage town in the County Donegal Development Plan. The 'at risk' buildings that have been identified by a methodical survey of the entire town and preparation of a Conservation Plan in 2018.

Individual buildings have been prioritised in accordance with BS7913: 2013 – "Guide to the Conservation of Historic Buildings" so that 'Priority 1' buildings require: "**Immediate work which should be put in hand without delay for public safety or health & safety reasons to prevent imminent damage or to arrest rapid deterioration**".



Kelly's Mill, above The Green – NIAH 40800303



Warehouse, The Quay - NIAH

Action 1 - Repair of Historic Buildings & Streets: Priority 2



Warehouse, Shore Road –RPS & NIAH 40800412



Sweeney's Bar, Bridge Street - NIAH 40800425



Houses, Castle Street - NIAH 40823065& 40823066; 40823112



Stewart Arms Hotel, Market Cross - RPS & NIAH 40823061



House & Shops, Castle Street – NIAH 40800418



The Corner House, Gambles Square – RPS & NIAH 40800402

'Priority 2' buildings require: "Urgent work which should be put in hand within weeks or months, or a year and a half at most. Failure to do so would be likely to result in significant further damage or deterioration and increased cost".

Action 1 - Repair of Historic Buildings & Streets: Priority 3



former Guild Hall, Castle Street – NIAH 40800416



former McDaid's, The Quay - NIAH40800409



Warehouse, The Mall – RPS & NIAH 40800214



Linen weaver's cottage, The Green – RPS & NIAH 40800208



Charles Kelly Ltd – NIAH 40800417



Houses, The Mall – NIAH 40823035 & 40823036



'The House on the Brae', Bridge Street
RPS & NIAH 40800401



House, Bridge Street
RPS & NIAH 40800413



Watchman's Huts, The Green – NIAH 40823109 & 40823109



Garage, Shore Road

'Priority 3' buildings require: "Necessary work which should be carried out before the next planned maintenance inspection (usually 5 years), for which there is time to plan, and which can be integrated with other work. This is work which is due in order to keep the building in a state of good repair and to maintain the value and usefulness of the estate."

Action 2 - Public Spaces for People

The public spaces identified within the study area which once formed a focus to people's daily lives are now dedicated to cars. There is an opportunity to address the deterioration of four significant civic spaces which would enhance the setting of this historic town.

Improving important public areas within Ramelton would provide shared space for socialising and encourage people to visit, spend time, and explore the town.

Actions

Short Term

- Support Tidy Towns activities & cleaning/maintenance of public spaces
- Update informational signage
- Improve street furniture & lighting
- Re-purpose under-utilised spaces

Long term

- Implement designs for each of the 4 main public spaces through major public realm works - Rural Regeneration & Development Fund (RRDF)/Town centre enhancement schemes/Town and Village renewal.
- Seek funding under RRDF, other funding sources
- Provide for events such as food & garden stalls, performance area, heritage trail, etc.
- Commission public art work
- Provide a children's playground

Guiding principles for the development of the public spaces have been drawn up for the following Specific Projects:

1. **The Market Cross**
2. **Gamble's Square**
3. **Market Green**
4. **The Quay**

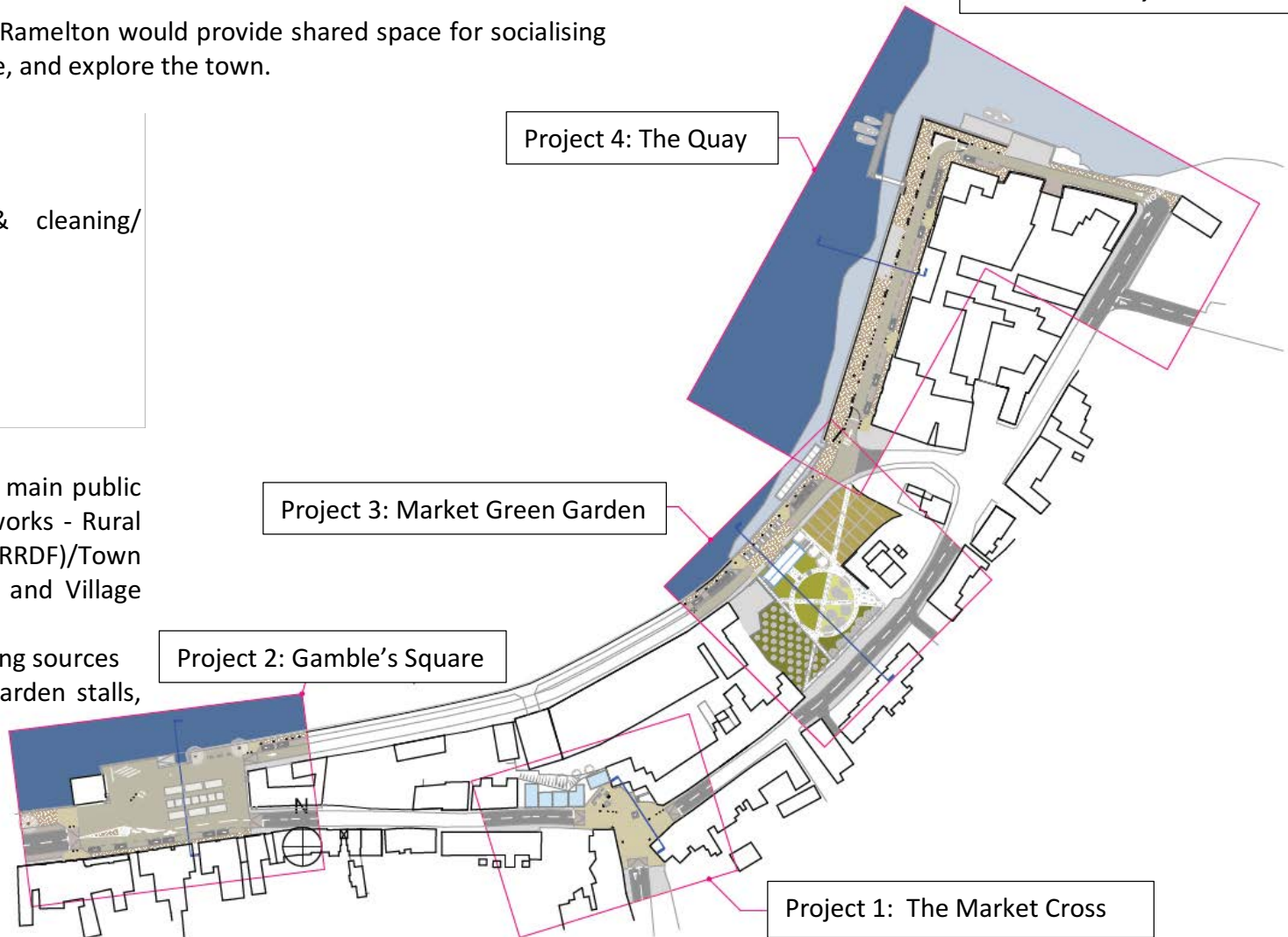

Action 2 – Public Spaces: Project 1

The Market Cross

The importance of the Market Cross as a meeting place is to be reinstated by making space for people. The proposal includes:

- Reinstatement of the road and footpath at the same level & give priority to pedestrians over vehicles
- Design paved surfaces & street furnishings to provide a civic space for use by visitors & local residents
- Provide seating within a sheltered sunny spot that is attractive to spend time in
- Install a new sculpture to replace the old market cross which signified the centre point of the town.
- Start of signposted walking routes
- A distance sign to other significant town centres
- Reinstatement of enclosure to the space by reinstatement of buildings on the north side that may be used for housing or tourism purposes in conjunction with completion of works to the adjacent abandoned hotel building
- Entrance to possible allotment gardens

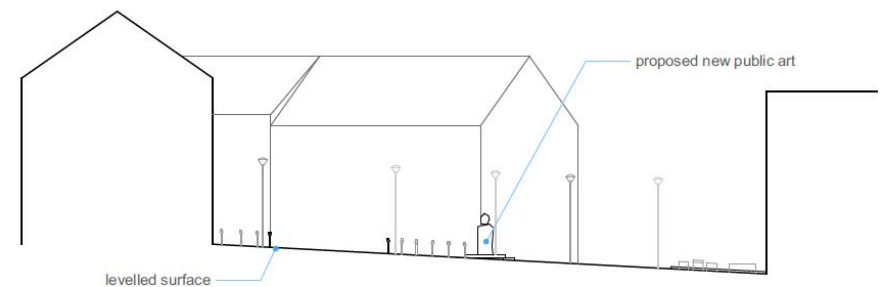
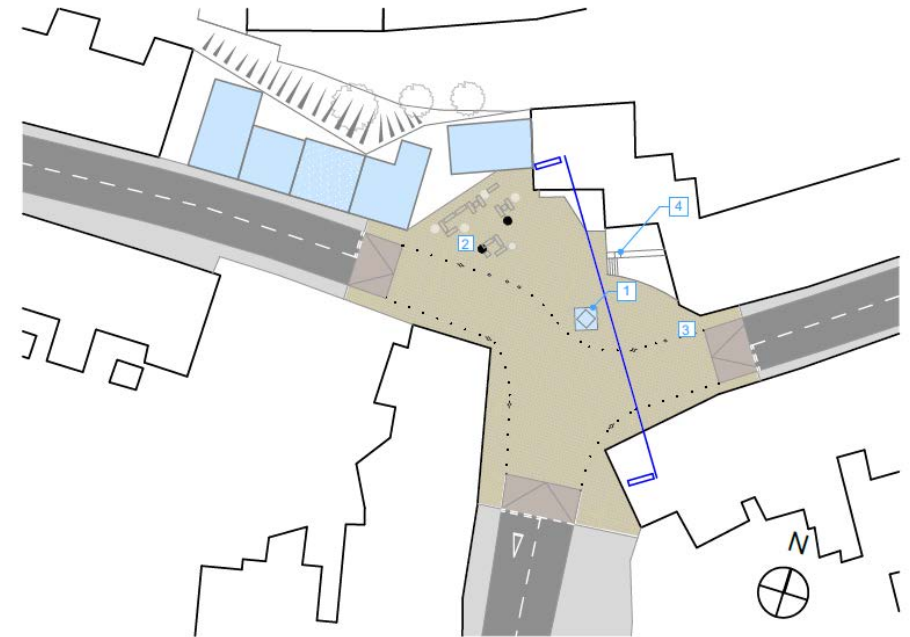

Action 2 – Public Spaces: Project 2 Gamble's Square

A commercial market space is to be created here that will benefit local people by improving the market offering and its accessibility and improve business for local shop keepers through the generation of new customers.

The proposal includes:

- Creation of a shared central space for market stalls and for outdoor café seating
- Re-creation of a civilised space giving vehicle traffic secondary importance; reinstatement of the road and footpath at the same level & give priority to pedestrians over vehicles.
- Install discrete traffic direction measures
- Design paved surfaces & street furnishings to provide a commercial civic space for use by visitors & local residents
- Extend the gravel pathway from the Mall to link with Shore Road
- Improve public seating adjacent to the riverside

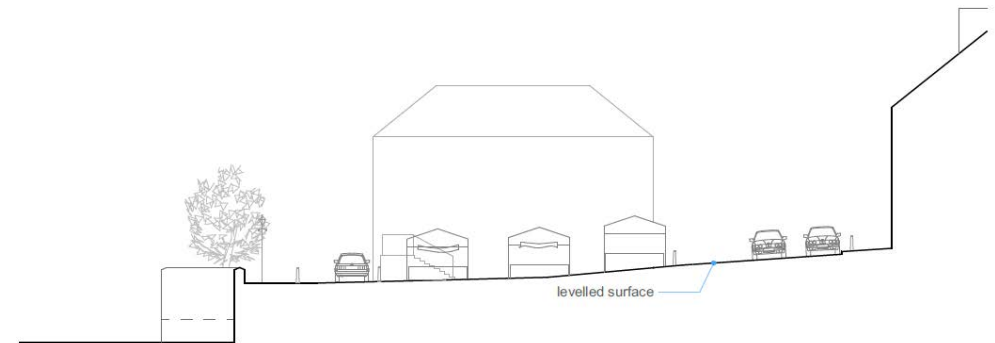
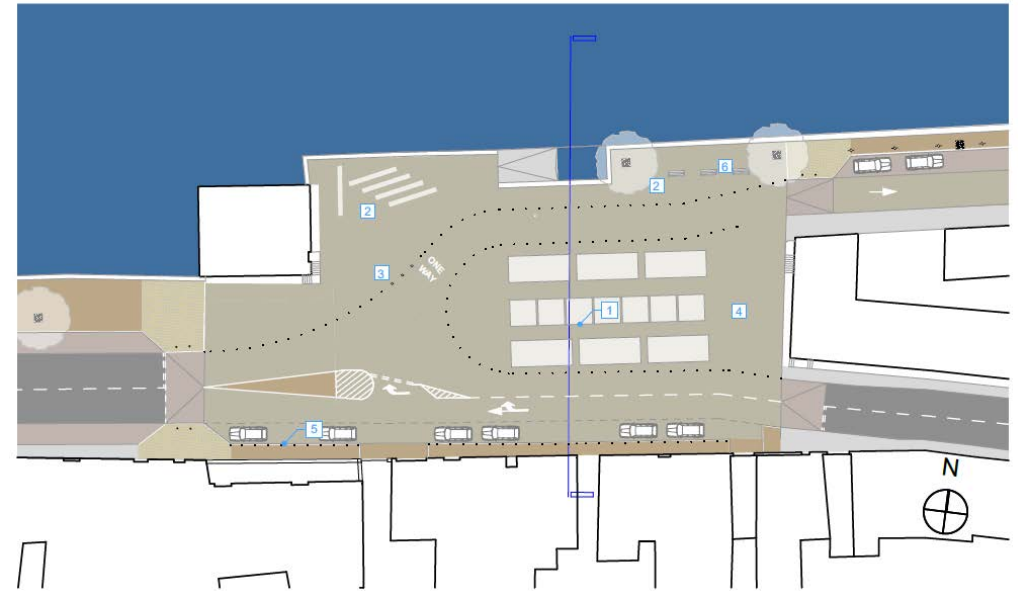

Action 2 – Public Spaces: Project 3 Market Green Garden

The existing large grassed area is to be developed to provide a new public garden that will attract people to visit Ramelton with the primary purpose of seeing it, at all times of the year. The design must be ground breaking and may involve working with a national or internationally known gardener.

This will also be a place to inspire local people who will participate in the development of the garden which will form the focus of a 'Transition Town' to provide a knowledge & resource centre to support allotments & guerrilla gardens throughout the town.

The proposal includes:

- Market Green – an urban edible garden, community plant & seedbank
- An open sided structure for open air exhibitions & events and for hosting regular artisan, gardener's and farmer's markets
- Retention of a pedestrian route linking Castle Street & the Quayside
- A children's play area

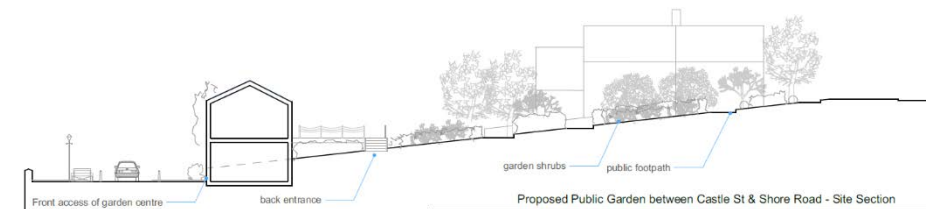
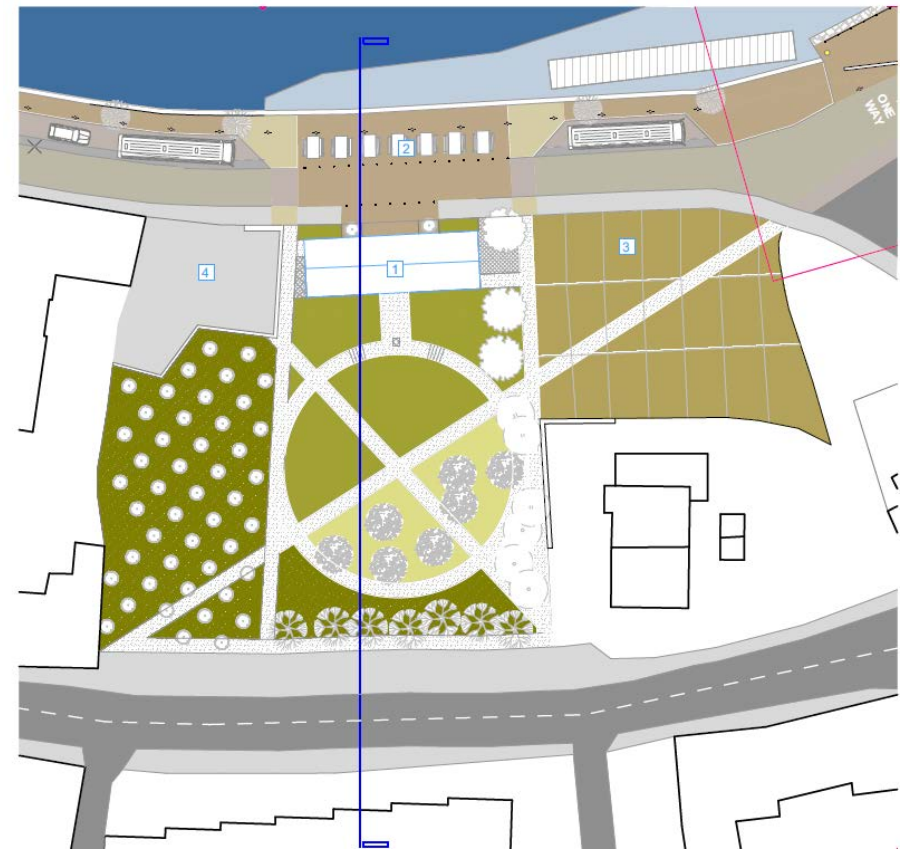

Action 2 – Public Spaces

Project 4: The Quay

The existing quayside was highlighted during initial consultation as being the most important area for improvement in the town. The priority is to reverse its decline through improvements to the public realm. These are now made possible through changes in ownership and sensitive development of the adjacent historic buildings.

The proposal includes:

- Retention of the quayside in use as a piece of maritime heritage
- Potential small craft moorings to increase marine use in conjunction with adjacent slipway
- Use of resilient & robust materials that can withstand occasional flooding & are consistent with the provincial historical character of the setting
- Reprioritisation of quayside for pedestrian use, one-way traffic, defined parking area
- Linking of gravel path walkway to the Shore road & the Mall
- Interpretation of maritime history, retention & restoration of existing maritime features – cobbles/sets, crane tracks, quayside wall, vernacular capstan features etc.

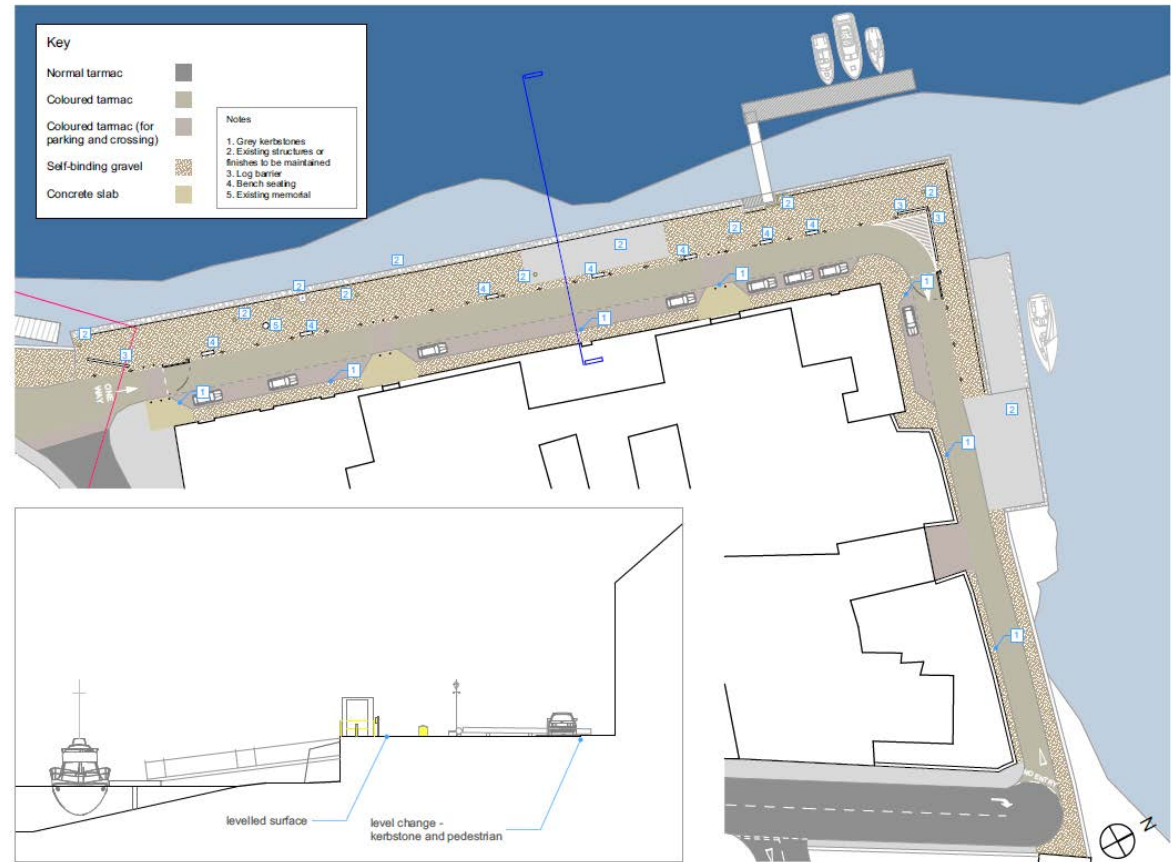

Action 3 – Commercial Activity

Over the course of the 20th century, commercial activity in the town has declined due to emigration, lack of investment and other factors that are common to many parts of rural Ireland. Ramelton has the great natural benefits in the form of its built heritage and natural environment and these are a unique resource to be utilised in this Action Plan.

The Actions that are proposed provide an opportunity for investment to be targeted at the town’s historic buildings and their setting, which will be of benefit to the town as a place to live and also as a tourism destination. This, in combination with the urgent need for investment in the ‘green economy’, specialist deep energy retrofit of traditional buildings, growth of interest in locally sourced food and hand-crafted produce, all have a potential to generate a vibrant future for the historic town of Ramelton.

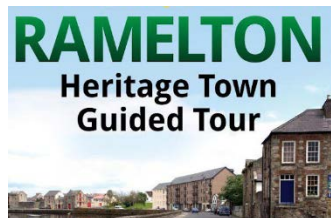
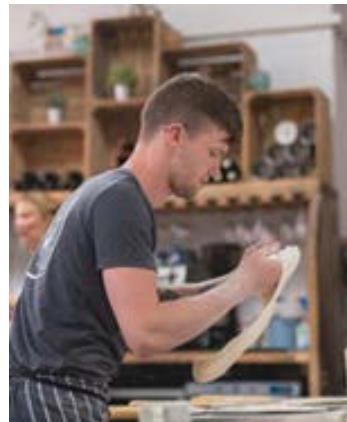

Actions

Short term

- Dress windows
- Promote local produce through pop-up shop initiatives
- Schedule of activities & events
- Promote the uptake of the Shop Front Improvement Grant Scheme
- Encourage removal of inappropriate shopfront signage & replace with appropriate signage
- Encourage employers to provide work experience for young people
- Create links with training & educational organisations, Donegal Food Trail, Failte Ireland/ Wild Atlantic Way, Donegal Garden Trail
- Create links with SEAI to explore community Better Energy Communities initiatives

Long term

- Development of a Digital Hub
- Development of workshops/studios & market space to accommodate local crafts & trades people
- Implement a Business Improvement Programme
- Grow the creative economy & culture-led economic development
- Town centre enhancement schemes – Town and Village Renewal
- Develop evening economy
- Develop ‘Green Economy’; training & implementation to support government policies for retrofit of 500,000 homes in Ireland by 2030

Action 4 – Historic Town Centre

According to the town centre 'health check' the commercial centre of Ramelton has moved westwards to follow the main road which passes through the town. This is an effect which has been emphasised by the absence of historic markets and other activities that once formed the very reason for the establishment of a town here. Action 4 – the rejuvenation of the Town Centre is an over-arching intention to which all of the proposed actions are designed to contribute.

There is an opportunity to re-establish the historic town centre and ensure a vibrant future for the historic town of Ramelton.

Actions

Short term

- Establish an Architectural Conservation Area & Update Record of Protected Structures
- Address vacancy and dereliction
- Promote a dedicated Ramelton Heritage Trail
- Encourage the creative reuse of empty buildings

Long term

- Re-introduce social and commercial function of abandoned public spaces
- Improve public infrastructure, in particular pedestrian infrastructure and provide new traffic arrangements and amenities
- Support 'living over the shop'
- Support the development of the arts sector - dedicated open arts space in the town
- Town centre enhancement schemes - Town & Village Renewal



Action 5 – Climate Change: Environmental Actions

The actions that are proposed as a result of the analysis of the historic town fabric of Ramelton follow best conservation practise, however the application of these principles at a practical level will require the adoption and development of these principles by the wider community.

‘Conservation’ in the context of this Action Plan is used in its widest possible sense, and refers not only to the care of the historic built fabric, but also the environment in which it is located and the energy used to construct and operate buildings over their lifetime. Traditional buildings, if properly cared for, may have an indefinite lifespan, and thus the repair of the historic environment is inherently energy efficient.

In the context of the current ‘climate emergency’ a number of possible actions have been identified which are discussed in more detail in the Appendix section of this document. Undoubtedly there will be more, especially in the context of the government climate action target of retrofitting 500,000 existing houses by 2030. This will require effort by whole communities if this target is to be achieved; the historic environment requires special consideration. Whilst this presents a huge challenge there is also an opportunity for training and the development of new skilled employment across all sectors of the economy.

It is proposed that the Transition Network provides one potential model to involve local people and provide the tools and inspiration that will be necessary for the successful implementation of this Action Plan and the transition to low carbon living. Partnership with bodies such as SEAI will assist in addressing technical & financial aspects of this part of the Action Plan.



Actions

Short term

- Repair & reuse buildings ‘At Risk’ – seek funding & advisory support
- Encourage upgrading of existing buildings & skills learning relevant to traditional solid wall building construction
- Encourage reuse of town centre houses through traffic calming & shared parking facilities incorporating electric charging points
- Improve public infrastructure, in particular, cycleways & pedestrian infrastructure to encourage walking
- Encourage carpooling & public transport options
- Investigate collective waste reduction & management measures
- Manage growth of alien invasive plants – Japanese Knotweed
- Encourage use of leftover public space for community planting/ guerilla gardens for pollinator plants, food & wildlife habitat
- Investigate flood resilience measures and predicted effects of sea level rises on the low-lying sections of the town
- Develop a community project for the provision of bat boxes & nest boxes on buildings to safeguard Swifts

Long term

- Maintain existing buildings to maximise use
- Regenerate town centre to provide for sustainable housing & a communal environment attractive to families, businesses & tourism
- Investigate reuse of existing mill structures for hydro-power generation
- Provide for the development of a Biodiversity Action Plan



Action 6 – Cycleways, Pathways & Walking Routes: The Walk/Slí na Slainte

There are networks of public walking routes, cycleways and greenways throughout Ireland which are based on physical activity as a pleasurable pastime, for tourism, and for health. The existing national Slí na Slainte network sponsored by the Irish Heart Foundation provide walking facilities for health, and it is proposed to establish a walking route here too.

In a post-carbon future, walking or cycling for journeys of short distance may also be necessary as well as desirable. An action of the plan is to improve pedestrian and cycle linkages by extending existing walking and cycling routes throughout Ramelton by providing the infrastructure to also make it a pleasurable activity. Starting at the Mall, the historic walk will be extended along the Shore Road to the Quayside, the existing Heritage Walk is proposed to be extended as a series of measured loop walks. A mapped wildlife and natural heritage walking route will be incorporated within these.

Within the town centre priority is to be provided to people over vehicles and roads serving public spaces civilized by giving space over to pedestrians and cyclists.

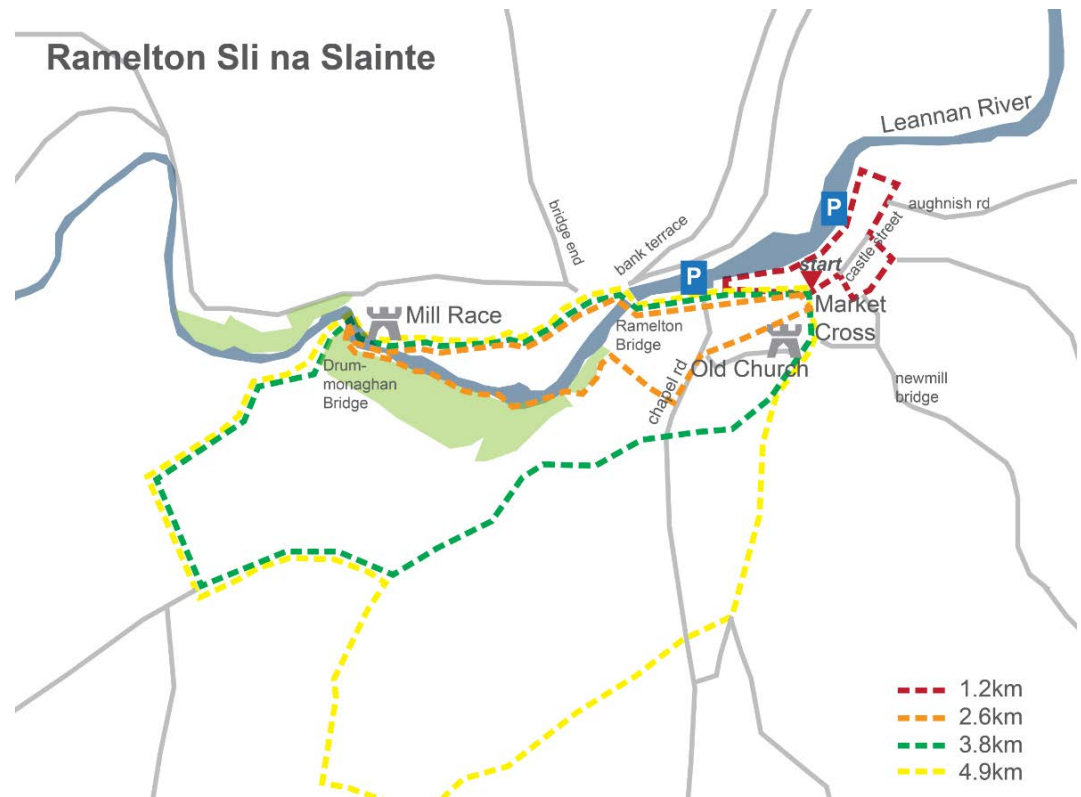

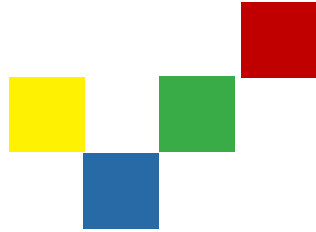

Bibliography

The proposed actions contained within this document have been informed by a methodical survey of 400 buildings in the Ramelton town centre area.

The survey findings form a substantial separate Appendix comprising a number of documents:

1. Maps (buildings numbered)

- Overview of town centre x1
- Town Neighbourhoods x 4

2. Database

- Record of 400 buildings in 2018

3. Field Records

- Data sheets & Photographs (1571 files; 3.6GB)

Survey findings are not due to be published, but are to be made available for review in public libraries and area planning offices.

General

- <https://www.heritagecouncil.ie/content/files/Heritage-Resource-Guide.pdf>

Map References

- Griffith Valuation Maps: <http://www.askaboutireland.ie/>
- OSI Historical mapping - <https://www.archaeology.ie/>
- UCD Library: <http://libguides.ucd.ie/findingmaps/>

History & Archaeology

- Camblin, G 1951 *The Town in Ulster*
- OS Memoirs: *Parishes of Co. Donegal II 1835-6 vol 39*
- Lewis, S 1837 *Topographical Dictionary of Ireland*
- McParlan, J 1801 *Statistical Survey of The County Of Donegal*. Dublin
- Rowan, A. *The Buildings of Ireland – Northwest Ulster* Penguin
- Irish Architectural Archive - *Dictionary of Irish Architects 1720-1940*: <http://www.dia.ie/>

Planning Policy & Legislation

- Planning and Development Act 2000 (as amended)
- Planning and Development Regulations 2001-2018
- County Donegal Development Plan 2018-2024

Research & Conference Papers

- Ballybrilliant: Heritage-led Regeneration in 5 Irish Towns* <https://www.heritagecouncil.ie/content/files/Ballybrilliant.pdf>
- Up the Town Built/Urban Heritage & Archaeology 2015*
- Place as Resource: Heritage Inspiring Innovation for Economic Growth* - <http://www.heritagecouncil.ie/events/past-conferences/place-as-resource-oct-2011/>

- Licciardi, G: *Supporting Economic Growth & Poverty Reduction: The Contribution of Historic City Rehabilitation and Cultural Heritage Conservation*
- Whitfield, C *The Economic Value of Ireland's Historic Environment*
- Geddes, D *The impacts that heritage environments have on towns and cities*
- Deep Energy Renovation of Traditional Buildings - Addressing Knowledge Gaps & Skills Training in Ireland* <https://www.heritagecouncil.ie/content/>
- Baker, P 2008 *Thermal Performance of Traditional Windows*. Edinburgh: Historic Scotland
- Wood, C et al. 2009 *Research into the Thermal Performance of Traditional Windows: Timber Sash Windows*. English Heritage
- Baker, P. 2008 *In Situ U-Value Measurements in Traditional Buildings*. Historic Scotland.
- Carrig Conservation et al. 2004 *Built to Last: the sustainable reuse of buildings*: Dublin City Council
- National Heritage Training Group, 2009 *Traditional Building Craft Skills - Skills Needs Analysis Of The Built Heritage Sector In Ireland*

Photographs & Drawings

- National Library of Ireland: <http://www.nli.ie/>
- Trinity college Library: <https://www.tcd.ie/Library/>

Building Conservation - Technical Guidance & Advice

- Dublin Civic Trust – *Irish Period Houses: A Conservation Guidance Manual*
- DAHG Advice Series: <http://www.ahg.gov.ie/heritage/heritage-publications/>
- Historic England/ English Heritage: <https://www.historicengland.org.uk/advice/technical-advice/>

- Historic Scotland – Technical Conservation Knowledge Base: <http://conservation.historic-scotland.gov.uk/publications>
- Glasgow West End Manual
- SPAB – Old House Handbook: A Practical Guide to Care & Repair
- SPAB – Old House Eco Handbook: A Practical Guide to Retro-Fitting for Energy Efficiency & Sustainability

Alteration & New Building

- Scott, F 2007 *On Altering Architecture*. Routledge
- Hunt, R (2017) *New Design for Old Buildings*. SPAB
- <https://www.designcouncil.org.uk/sites/default/files/asset/document/building-in-context-new-development-in-historic-areas.pdf>
- Managing the Historic Landscape (Vienna: UNESCO World Heritage Centre, 2005)
- Design in Context: Guidelines For Infill Development In The Historic Environment <https://www.environment.nsw.gov.au/resources/heritagebranch/heritage/DesignInContext.pdf>
- Design Manual for Urban Roads & Streets* (2013) Department of Environment, Community and Local Government

Appendix – Survey Mapping

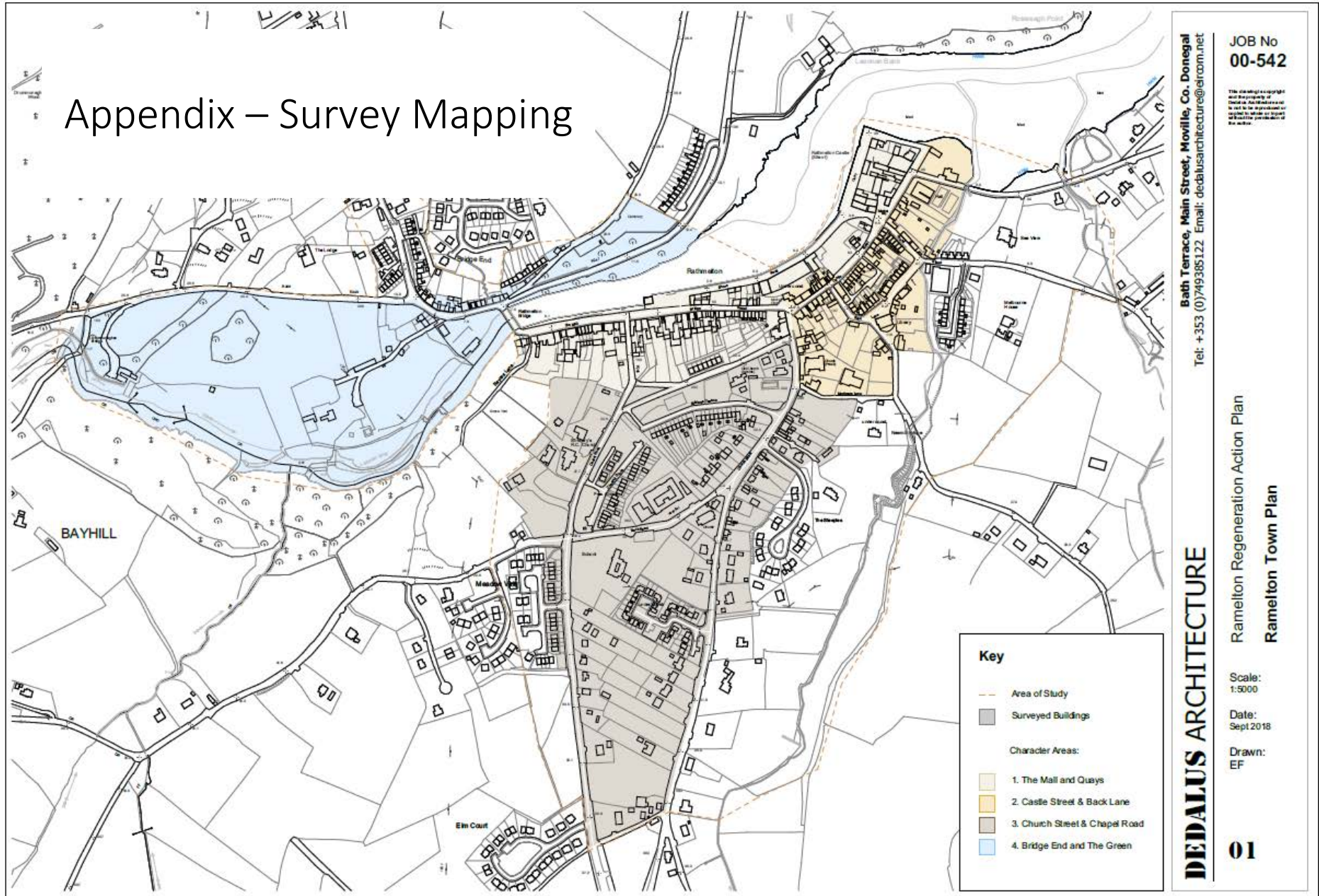

DEDALUS ARCHITECTURE
 Bath Terrace, Main Street, Moville, Co. Donegal
 Tel: +353 (0)749385122. Email: dedalusarchitecture@eircom.net

JOB No
00-542

The drawings copyright and the property of Dedalus Architecture are not to be reproduced in any form or by any means without the prior written permission of the author.

RAMELTON TOWN PLAN

Ramelton Regeneration Action Plan
 Ramelton Town Plan

Scale:
 1:5000

Date:
 Sept 2018

Drawn:
 EF

01

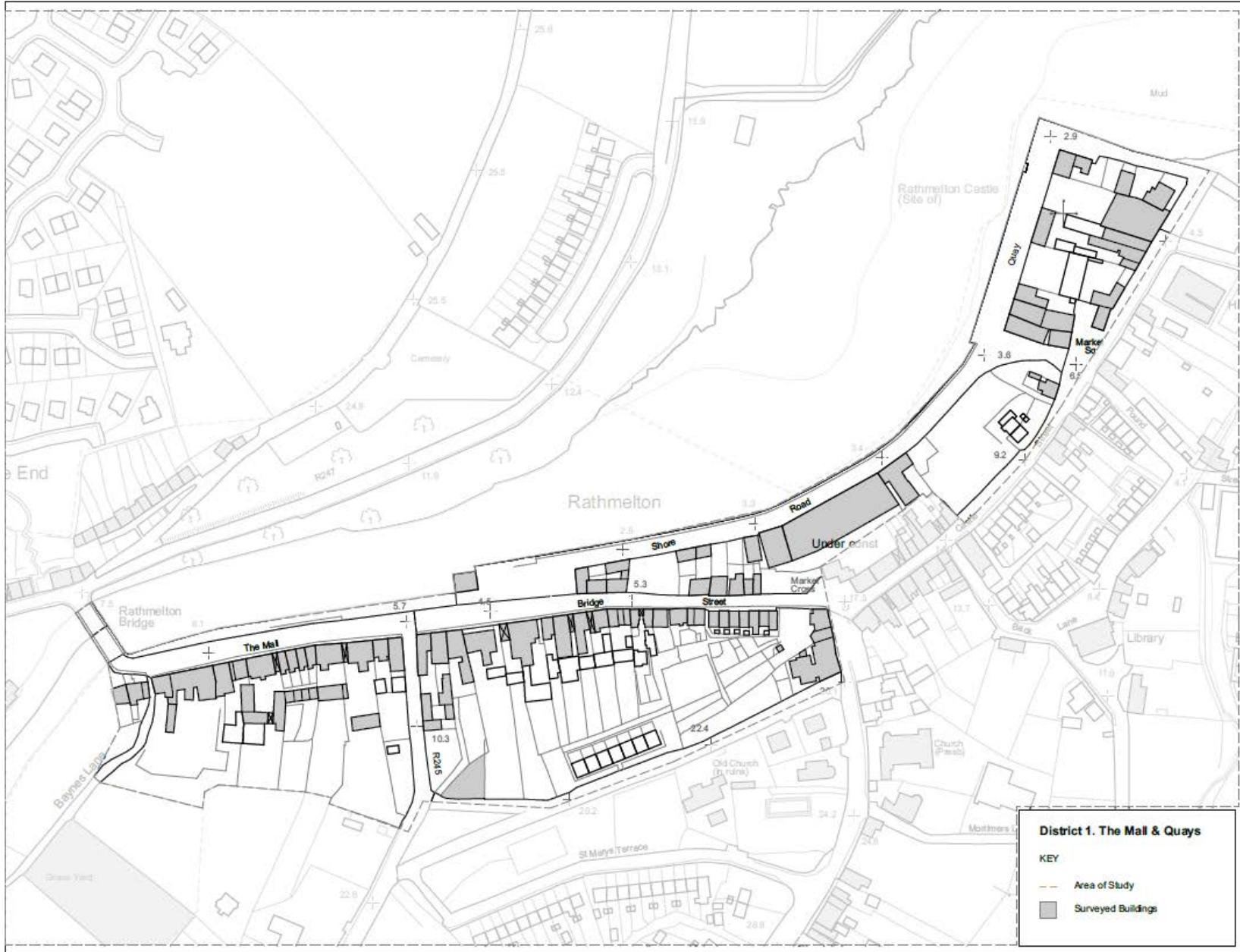

DEDALUS ARCHITECTURE
 Bath Terrace, Main Street, Moville, Co. Donegal
 Tel: +353 (0)749385122 Email: dedalusarchitecture@eircom.net

JOB No
00-542

The copyright in this plan and any drawings or documents is reserved by DEDALUS ARCHITECTURE. No part of this plan or any drawings or documents may be reproduced or transmitted in any form or by any means, electronic, mechanical, photocopying, recording, or by any information storage and retrieval system, without the prior written permission of DEDALUS ARCHITECTURE.

Ramelton Regeneration Action Plan
Buildings Surveyed 1. The Mall and Quays

Scale:
 1:2000
 Date:
 Sept 2018
 Drawn:
 EF

DEDALUS ARCHITECTURE

02

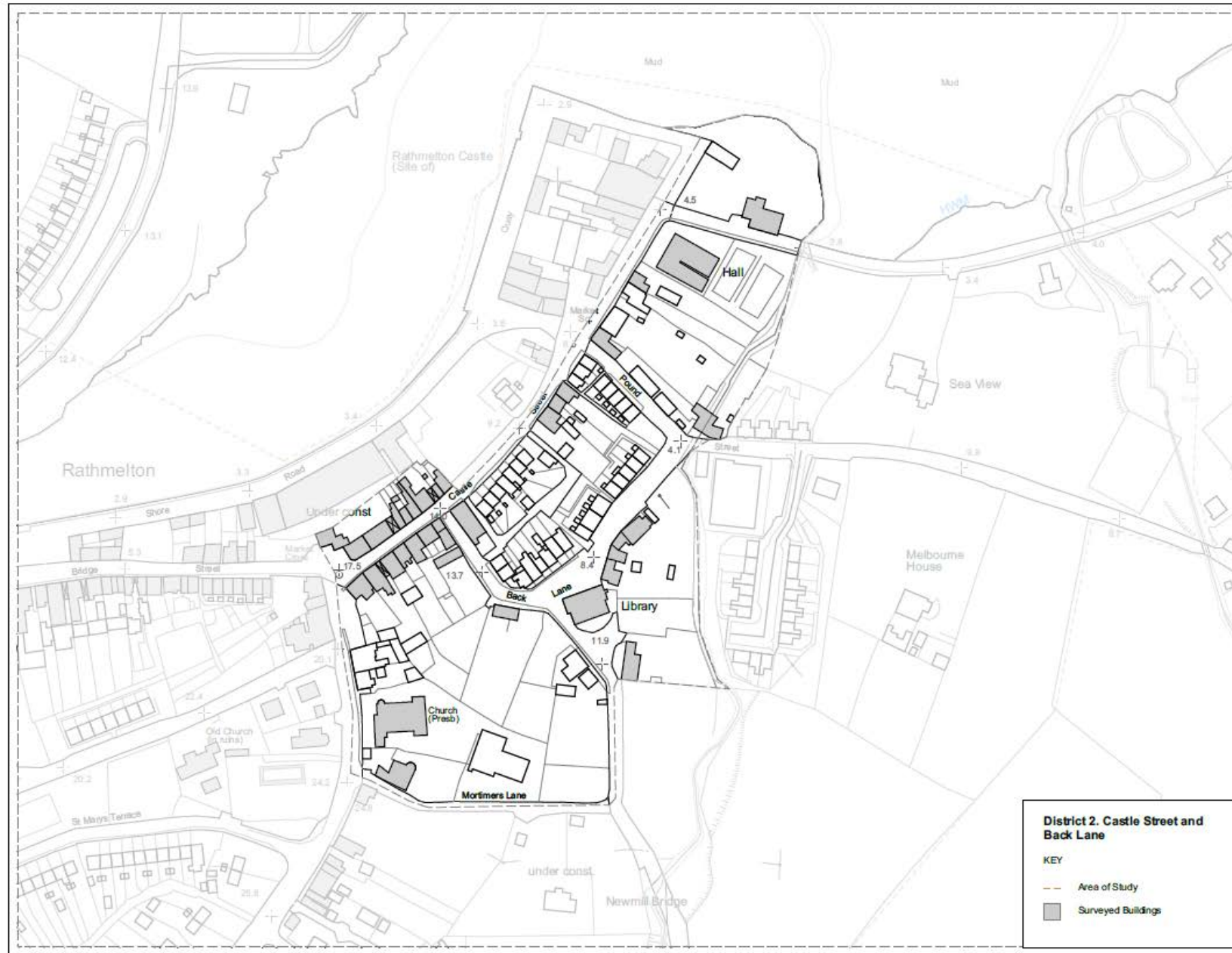

District 2. Castle Street and Back Lane

KEY

- Area of Study
- Surveyed Buildings

DEDALUS ARCHITECTURE

Ramelton Regeneration Action Plan
Buildings Surveyed 2. Castle Street and Back Lane

Bath Terrace, Main Street, Moville, Co. Donegal
Tel: +353 (0)749385122 Email: dedalusarchitecture@eircom.net

JOB No
00-542

The copyright in this document and any drawings or plans contained herein is reserved by Dedalus Architecture and shall remain the property of Dedalus Architecture.

Scale:
1:2000

Date:
Sept 2018

Drawn:
EF

03



District 3. Church Street and Chapel Road

KEY

- - - Area of Study
- Surveyed Buildings

DEDALUS ARCHITECTURE
 Bath Terrace, Main Street, Moville, Co. Donegal
 Tel: +353 (0)749385122 Email: dedalusarchitecture@eircom.net

JOB No
00-542

The drawing copyright and the property of Dedalus Architecture is not to be reproduced or used for any purpose without the written consent of the author.

Ramelton Regeneration Action Plan
Buildings Surveyed 3. Church Street and Chapel Road

Scale:
 1:2000
 Date:
 Sept 2018
 Drawn:
 EF

04

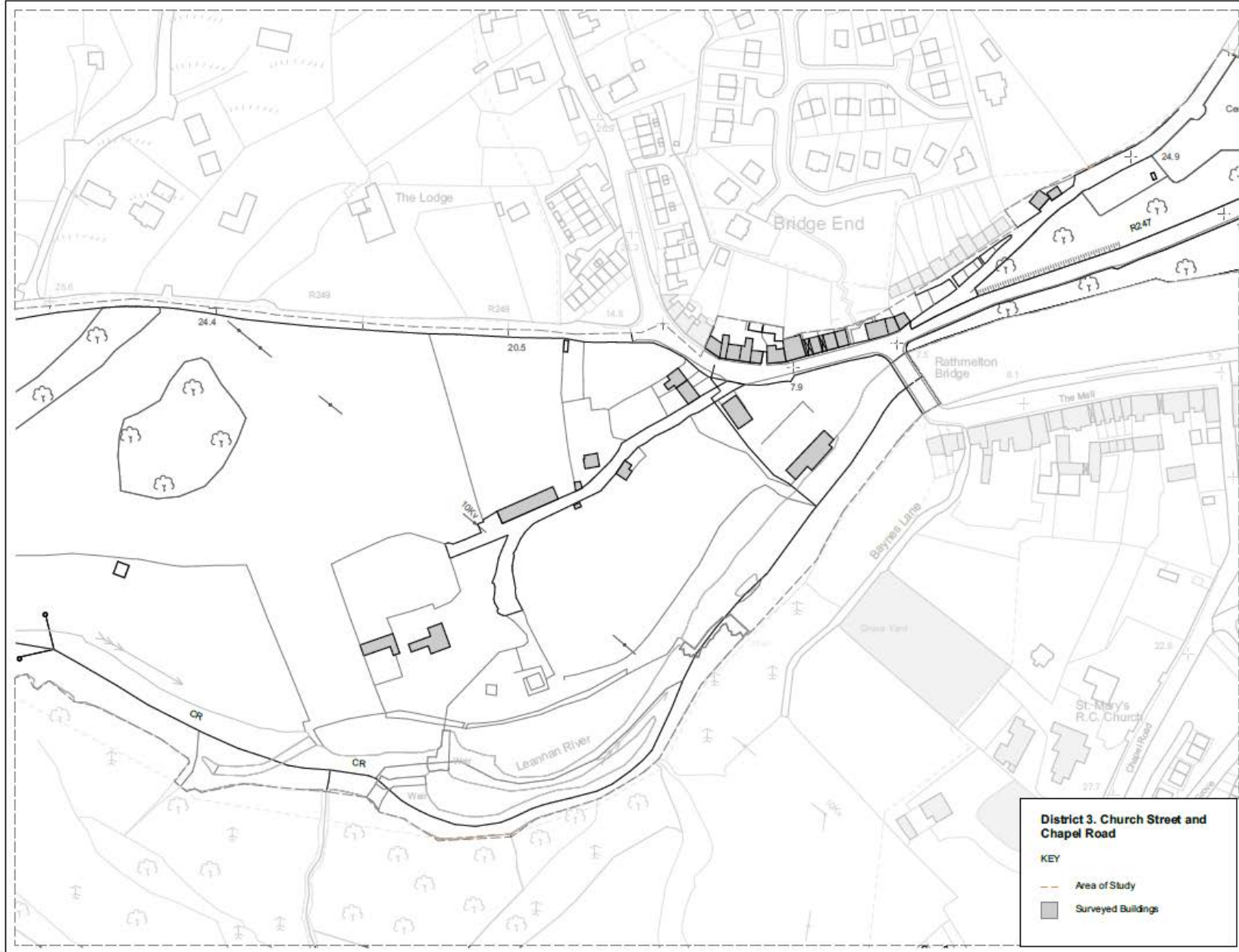

Dedalus Architecture
 Bath Terrace, Main Street, Moville, Co. Donegal
 Tel: +353 (0)749385122 Email: dedalusarchitecture@eircom.net

JOB No
00-542

The analysis, design and drawings of this document are not to be reproduced or applied to other projects without the written consent of the author.

DEDALUS ARCHITECTURE

Ramelton Regeneration Action Plan
Buildings Surveyed 4. Bridge End and The Green

Scale:
 1:2000
 Date:
 Sept 2018
 Drawn:
 EF

05

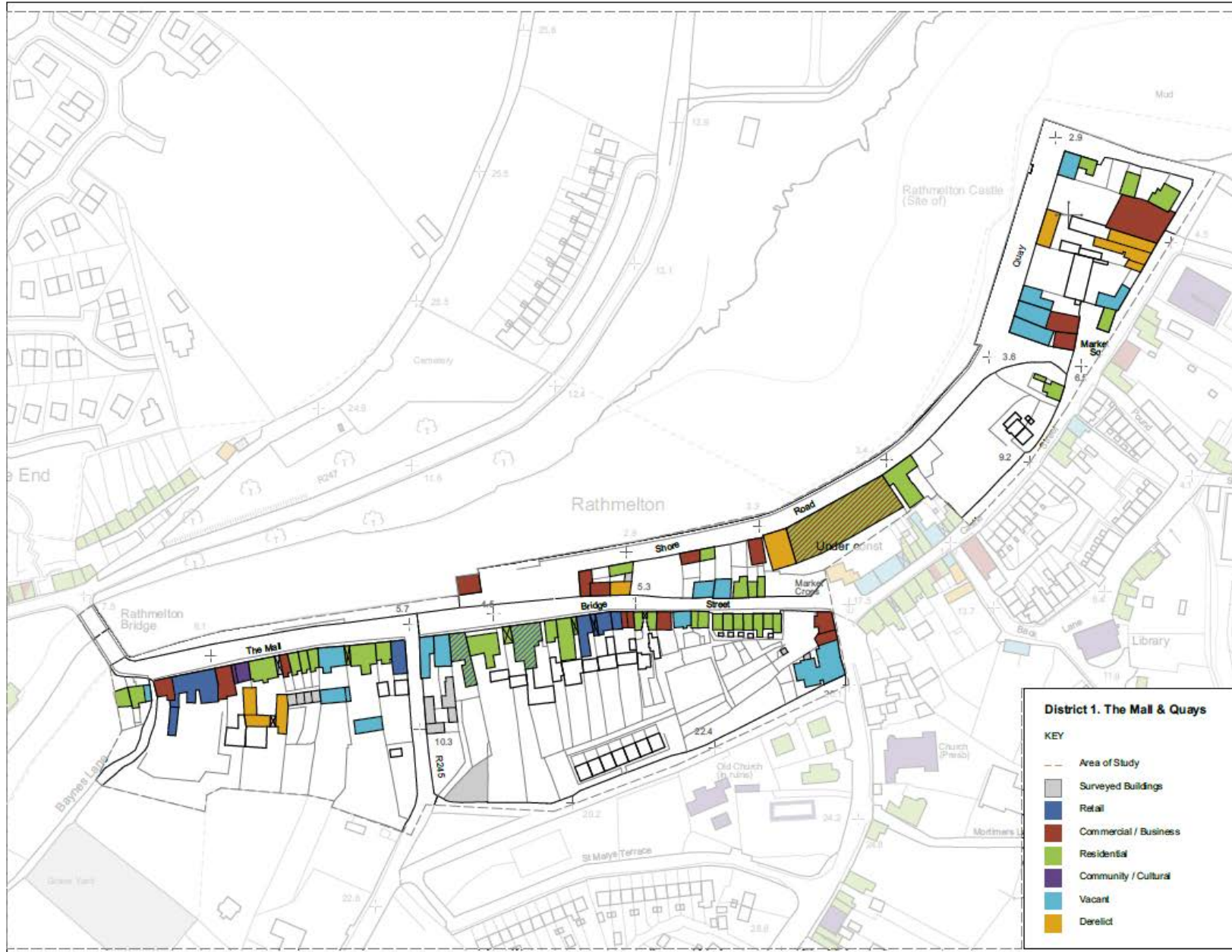

DEDALUS ARCHITECTURE
 Bath Terrace, Main Street, Moville, Co. Donegal
 Tel: +353 (0)749385122 Email: dedalusarchitecture@eircom.net

JOB No
00-542

The design copyright and ownership of this document and its contents are reserved in whole or in part by the author.

Rathmelton Regeneration Action Plan
Building Types - 1. The Mall and Quays

Scale:
 1:2000

Date:
 Sept 2018

Drawn:
 EF

06

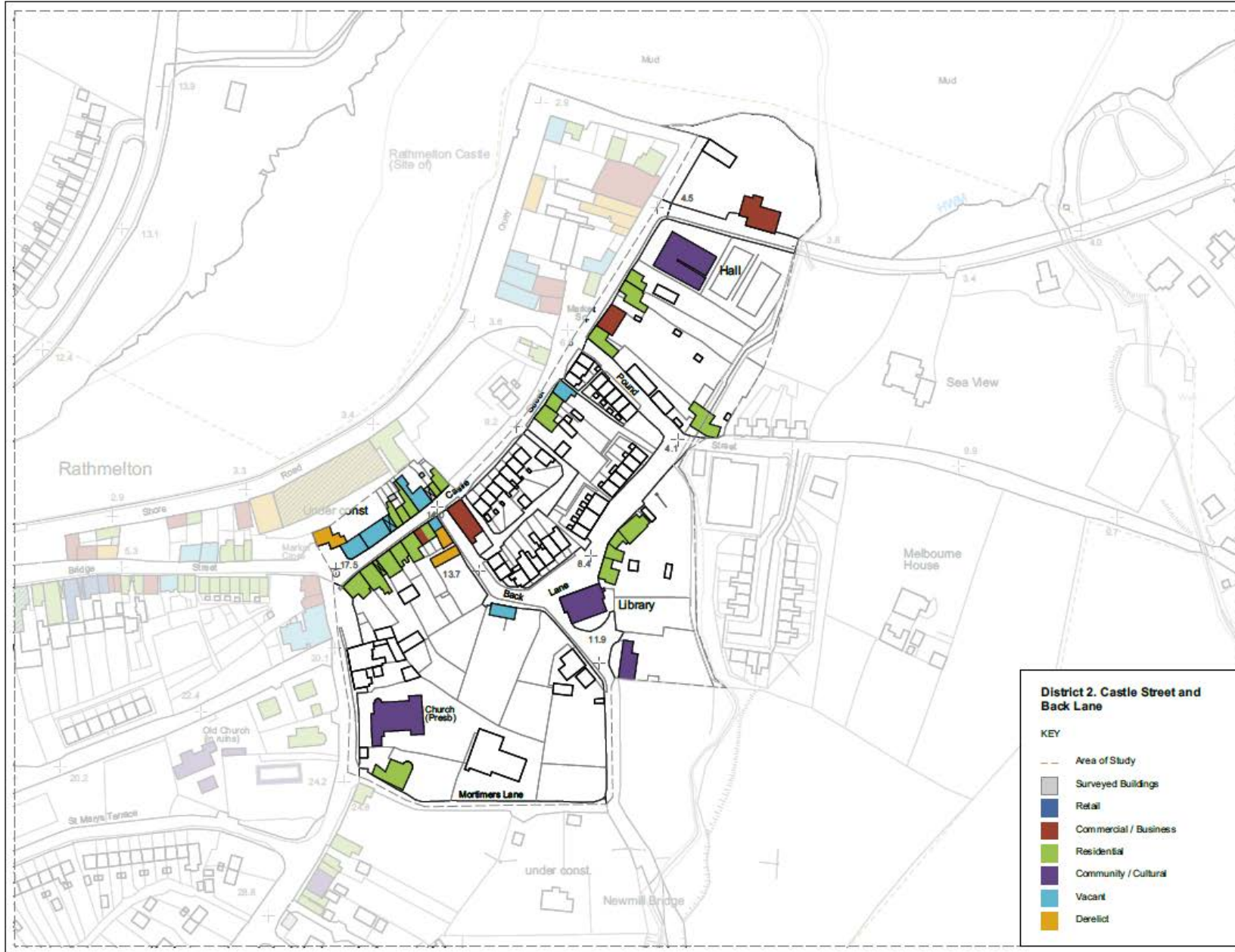

District 2. Castle Street and Back Lane

KEY

- Area of Study
- Surveyed Buildings
- Retail
- Commercial / Business
- Residential
- Community / Cultural
- Vacant
- Derelict

DEDALUS ARCHITECTURE
 Bath Terrace, Main Street, Moville, Co. Donegal
 Tel: +353 (0)749385122 Email: dedalusarchitecture@eircom.net

Ramelton Regeneration Action Plan
Building Types - 2. Castle Street and Back Lane

JOB No
00-542

Scale:
 1:2000

Date:
 Sept 2018

Drawn:
 EF

07

The design copyright and ownership of this document and its contents shall remain the property of Dedalus Architecture and shall not be reproduced or used in any form without the prior written consent of the author.



District 3. Church Street and Chapel Road

KEY

- Area of Study
- Surveyed Buildings
- Retail
- Commercial / Business
- Residential
- Community / Cultural
- Vacant
- Derelict

DEDALUS ARCHITECTURE
 Bath Terrace, Main Street, Moville, Co. Donegal
 Tel: +353 (0)749385122. Email: dedalusarchitecture@eircom.net

Ramelton Regeneration Action Plan
Building Types - 3. Church Street and Chapel Road

Scale: 1:2000
 Date: Sept 2018
 Drawn: EF
08

JOB No
00-542

The design copyright and responsibility of Dedalus Architecture is not to be transferred or used to make or copy any other products or services without the author's consent.

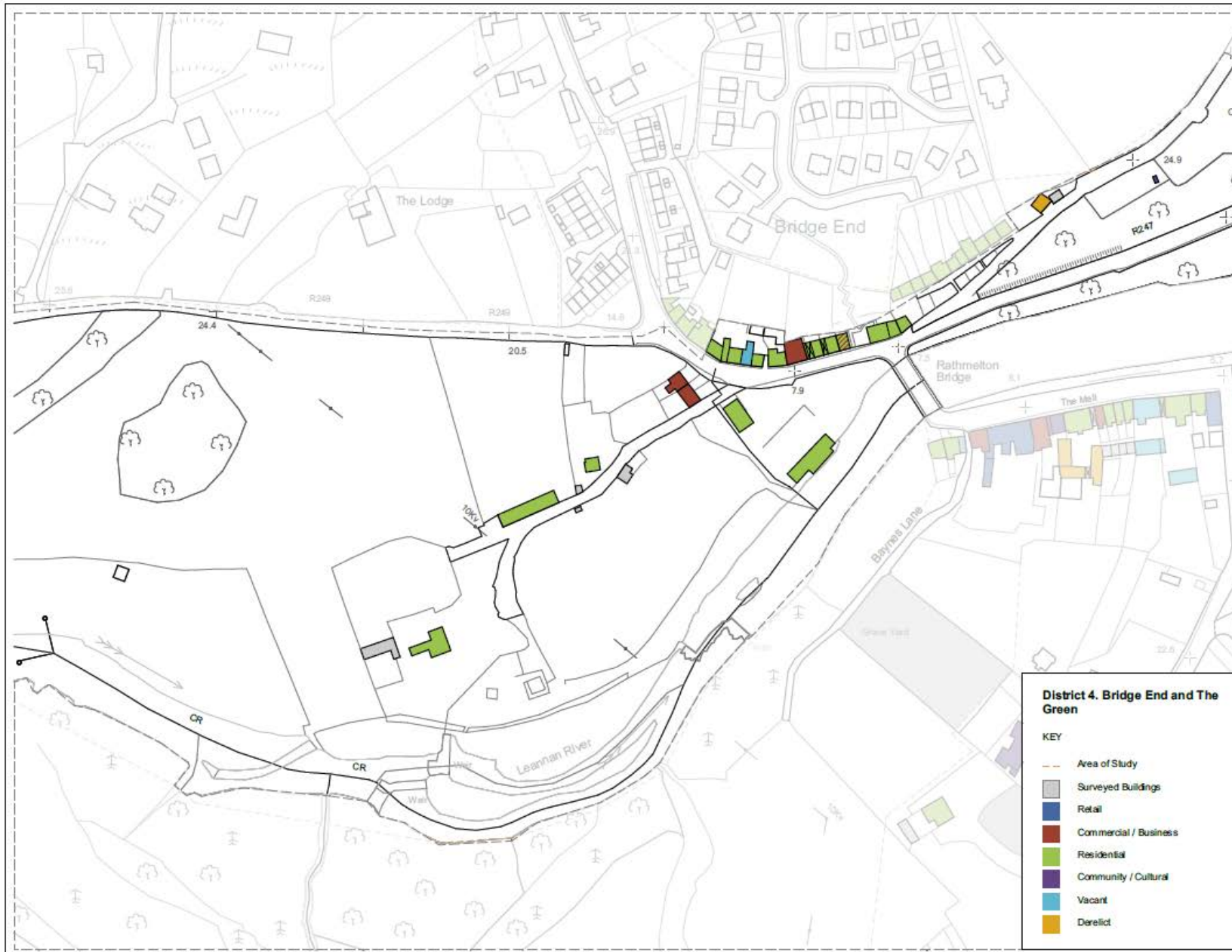

Bath Terrace, Main Street, Moville, Co. Donegal
 Tel: +353 (0)749385122 Email: dedalusarchitecture@eircom.net

JOB No
00-542

The design copyright and ownership of this Action Plan is not the responsibility of Dedalus Architecture. It is subject to change or input from the planning authority.

DEDALUS ARCHITECTURE

Ramelton Regeneration Action Plan
Building Types - 4. Bridge End and The Green

Scale:
 1:2000
 Date:
 Sept 2018
 Drawn:
 EF

09

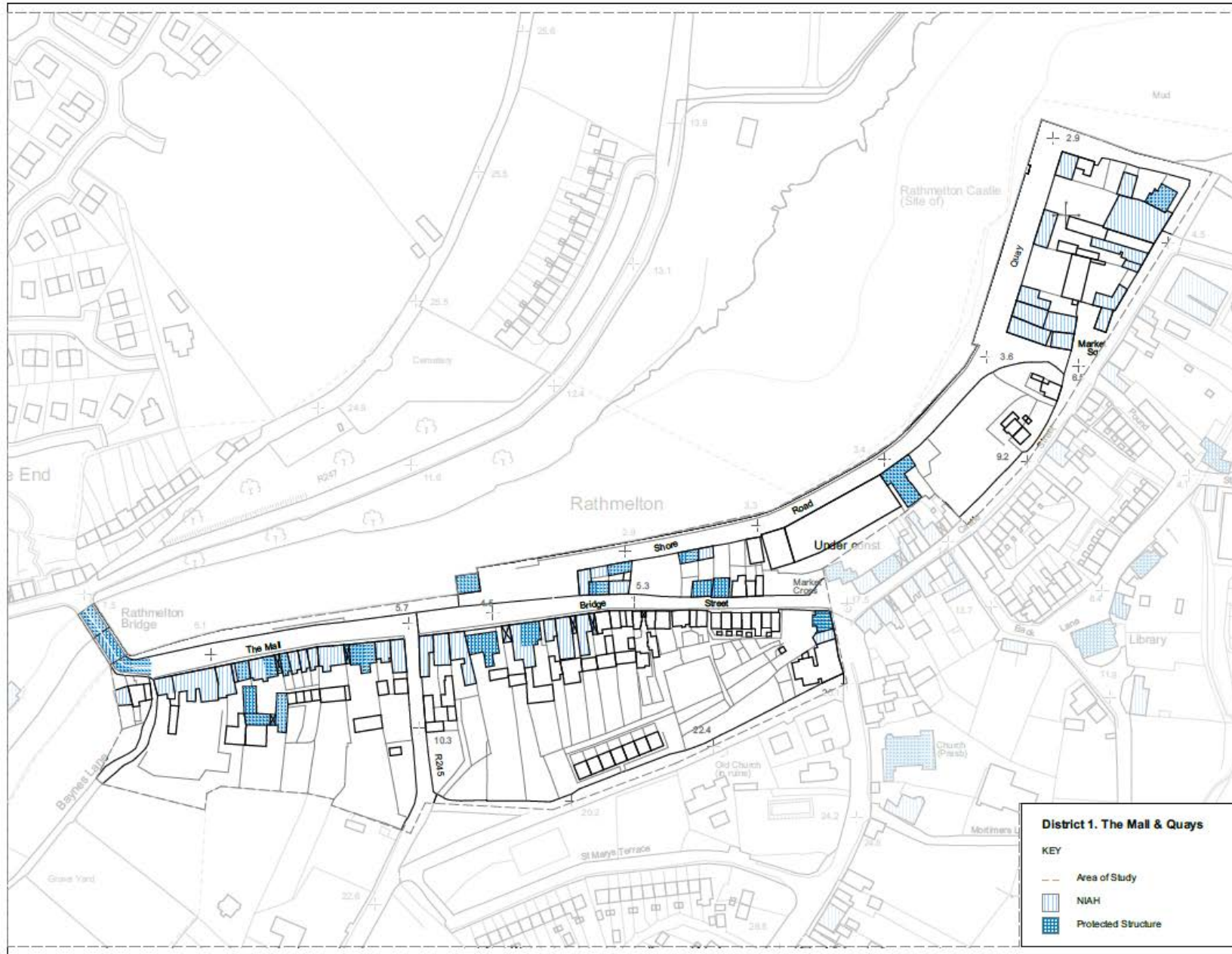

DEDALUS ARCHITECTURE
 Bath Terrace, Main Street, Moville, Co. Donegal
 Tel: +353 (0)749385122 Email: dedalusarchitecture@eircom.net

JOB No
00-542

The design copyright and drawings of this Action Plan are not to be reproduced without the prior written consent of the author.

Ramelton Regeneration Action Plan
Architecture Value - 1. The Mall and Quays

Scale:
 1:2000
 Date:
 Sept 2018
 Drawn:
 EF

10

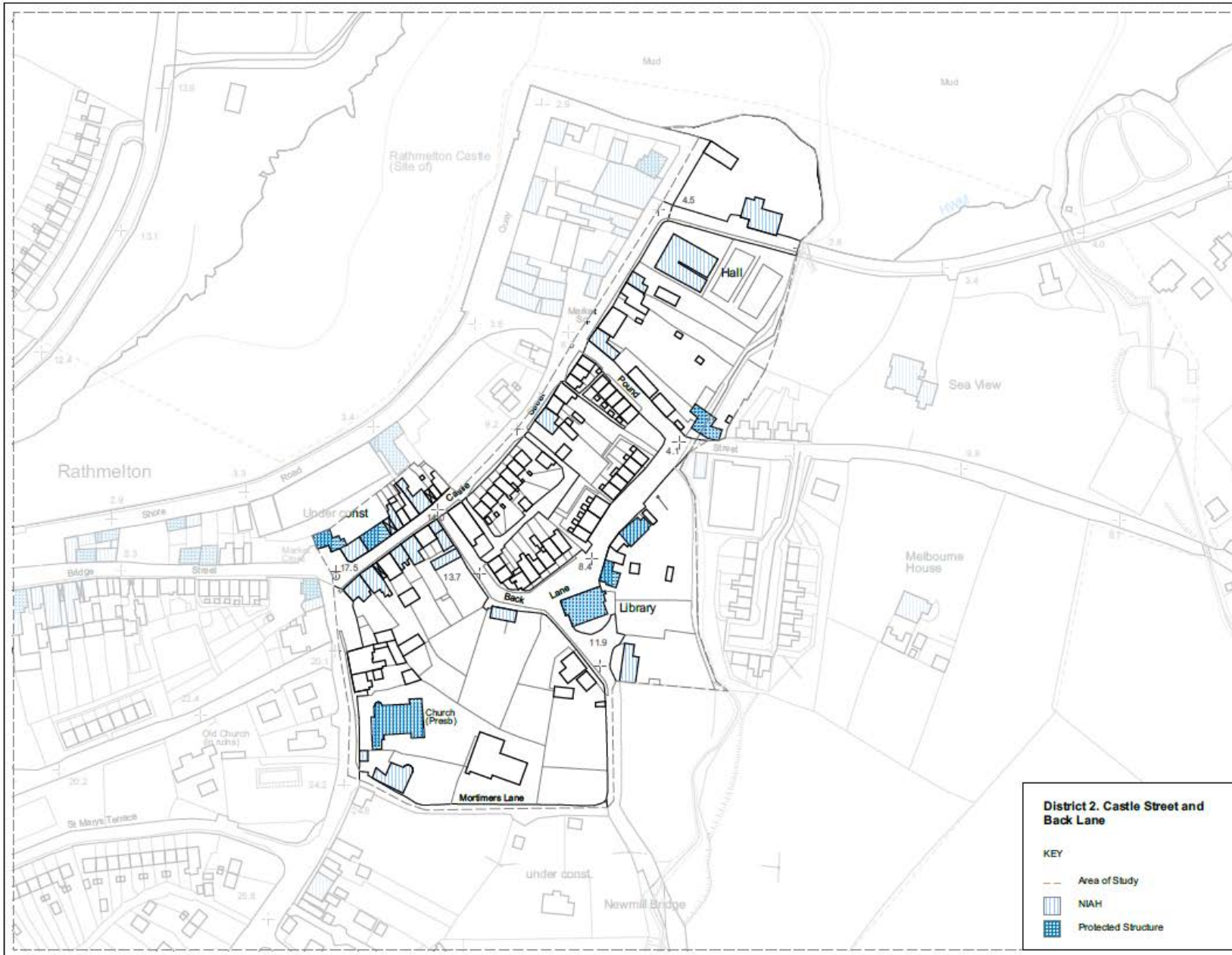

District 2. Castle Street and Back Lane

KEY

- - - Area of Study
- ▨ NIAH
- ▣ Protected Structure

DEDALUS ARCHITECTURE
 Bath Terrace, Main Street, Moville, Co. Donegal
 Tel: +353 (0)749385122 Email: dedalusarchitecture@arcom.net

Rathmelton Regeneration Action Plan
Architecture Value - 2. Castle Street and Back Lane

Scale: 1:2000
 Date: Sept 2018
 Drawn: EF

JOB No
00-542

This drawing is copyright and the property of DEDALUS ARCHITECTURE and is not to be reproduced or copied in whole or in part without the permission of the author.

11



District 3. Church Street and Chapel Road

KEY

- Area of Study
- ▨ NIAH
- ▣ Protected Structure

DEDALUS ARCHITECTURE

Bath Terrace, Main Street, Moville, Co. Donegal
 Tel: +353 (0)749385122 Email: dedalusarchitecture@eircom.net

Ramelton Regeneration Action Plan
Architecture Value - 3. Church Street and Chapel Road

Scale: 1:2000
 Date: Sept 2018
 Drawn: EF

JOB No 00-542

The design copyright and ownership in this Architecture and Planning Report is retained by DEDALUS ARCHITECTURE and no part of it may be reproduced without the prior written consent of the author.

12

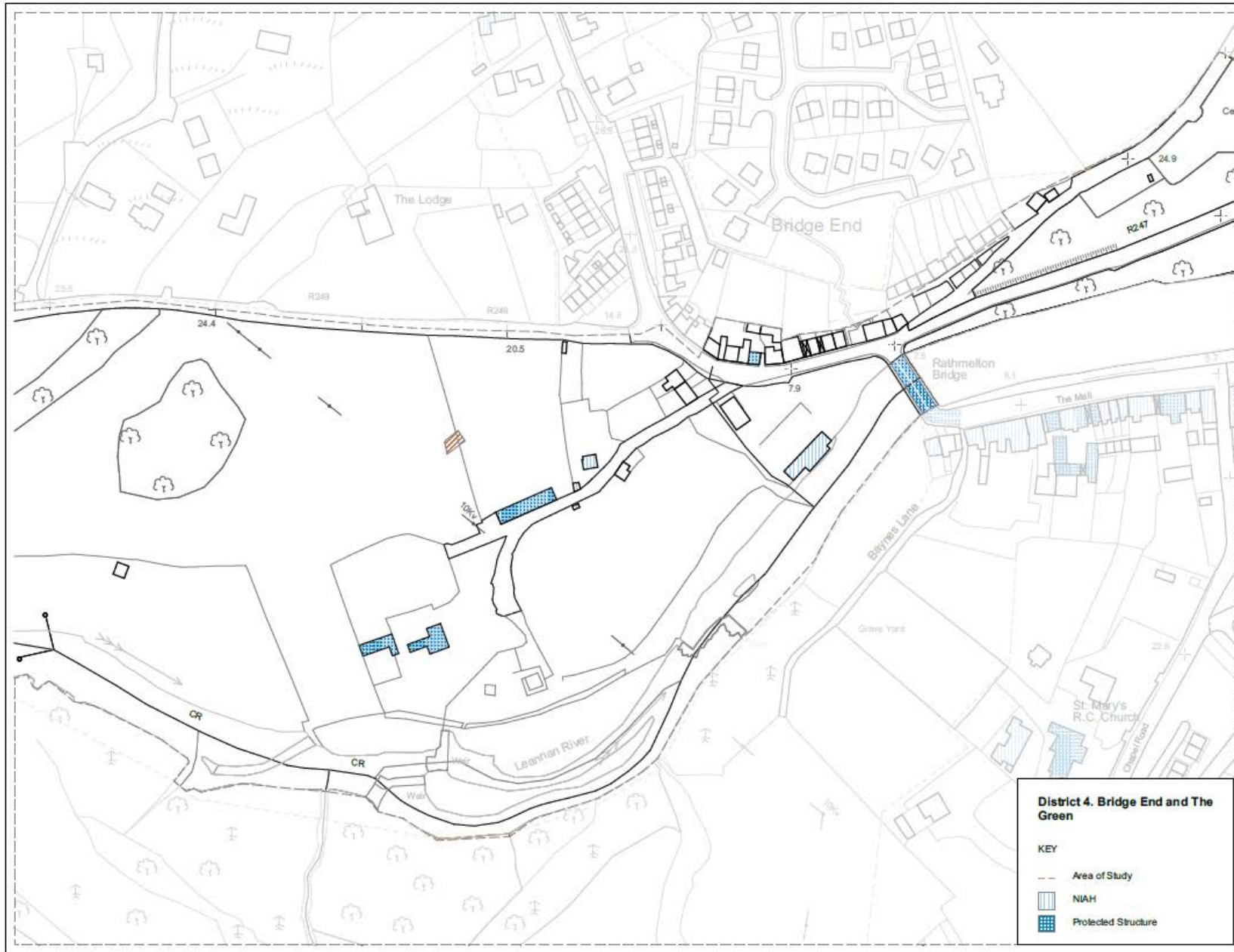

District 4. Bridge End and The Green

KEY

- Area of Study
- ▨ NIAH
- ▩ Protected Structure

DEDALUS ARCHITECTURE
 Bath Terrace, Main Street, Moville, Co. Donegal
 Tel: +353 (0)749385122 Email: dedalusarchitecture@eircom.net

JOB No
00-542

The drawing copyright and ownership of DEDALUS ARCHITECTURE is not to be reproduced or copied in whole or part without the permission of the author.

Ramelton Regeneration Action Plan
Architecture Value - 4. Bridge End and The Green

Scale:
 1:2000
 Date:
 Sept 2018
 Drawn:
 EF

13

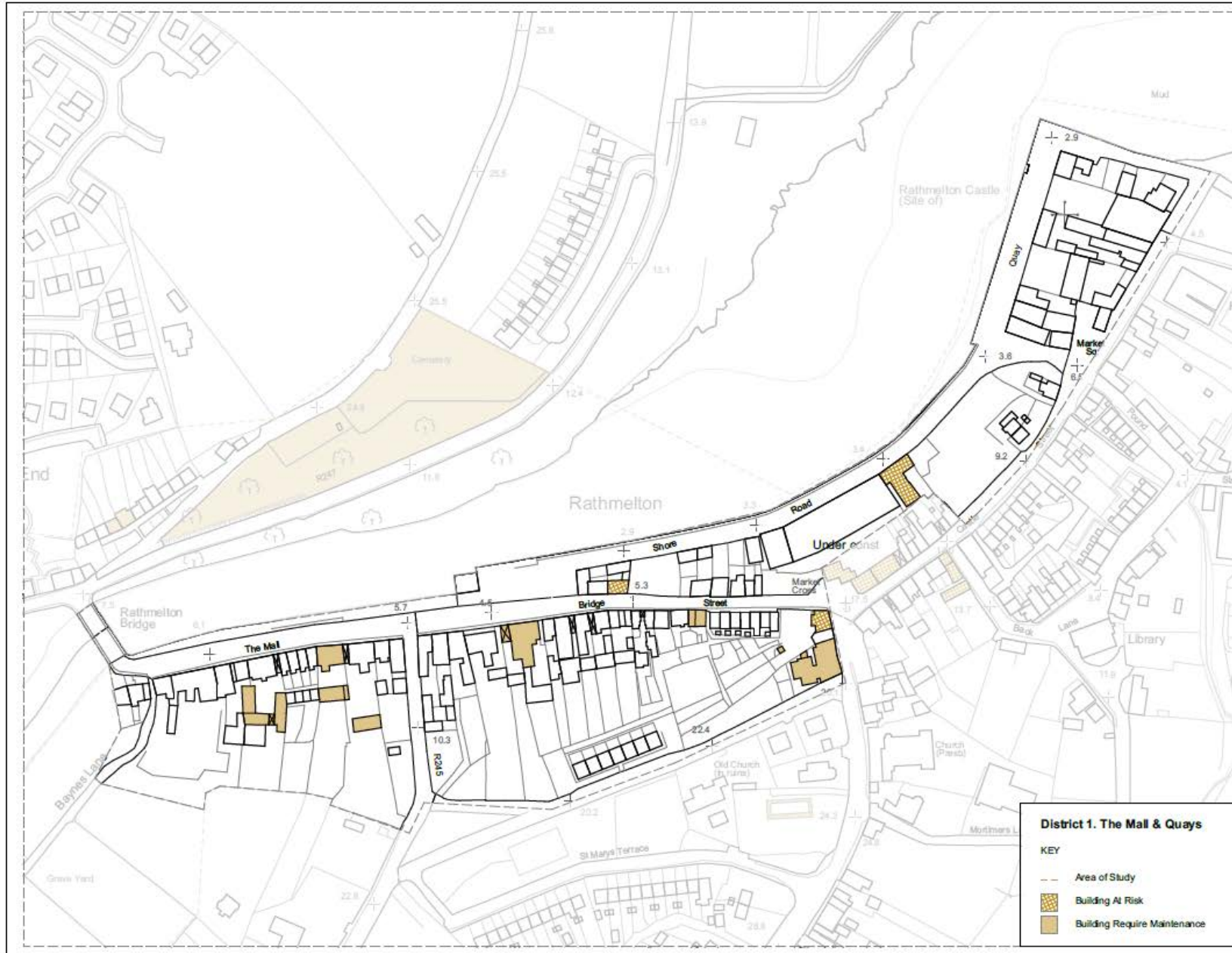

District 1. The Mall & Quays

KEY

- - - Area of Study
- Building At Risk
- Building Require Maintenance

DEDALUS ARCHITECTURE
 Bath Terrace, Main Street, Moville, Co. Donegal
 Tel: +353 (0)749385122. Email: dedalusarchitecture@eircom.net

JOB No
00-542

This drawing is copyright and the property of DEDALUS ARCHITECTURE. It is not to be reproduced or used in any way without the prior written permission of the author.

Ramelton Regeneration Action Plan
Buildings at Risk - 1. The Mall and Quays

Scale: 1:2000
 Date: Sept 2018
 Drawn: EF

14

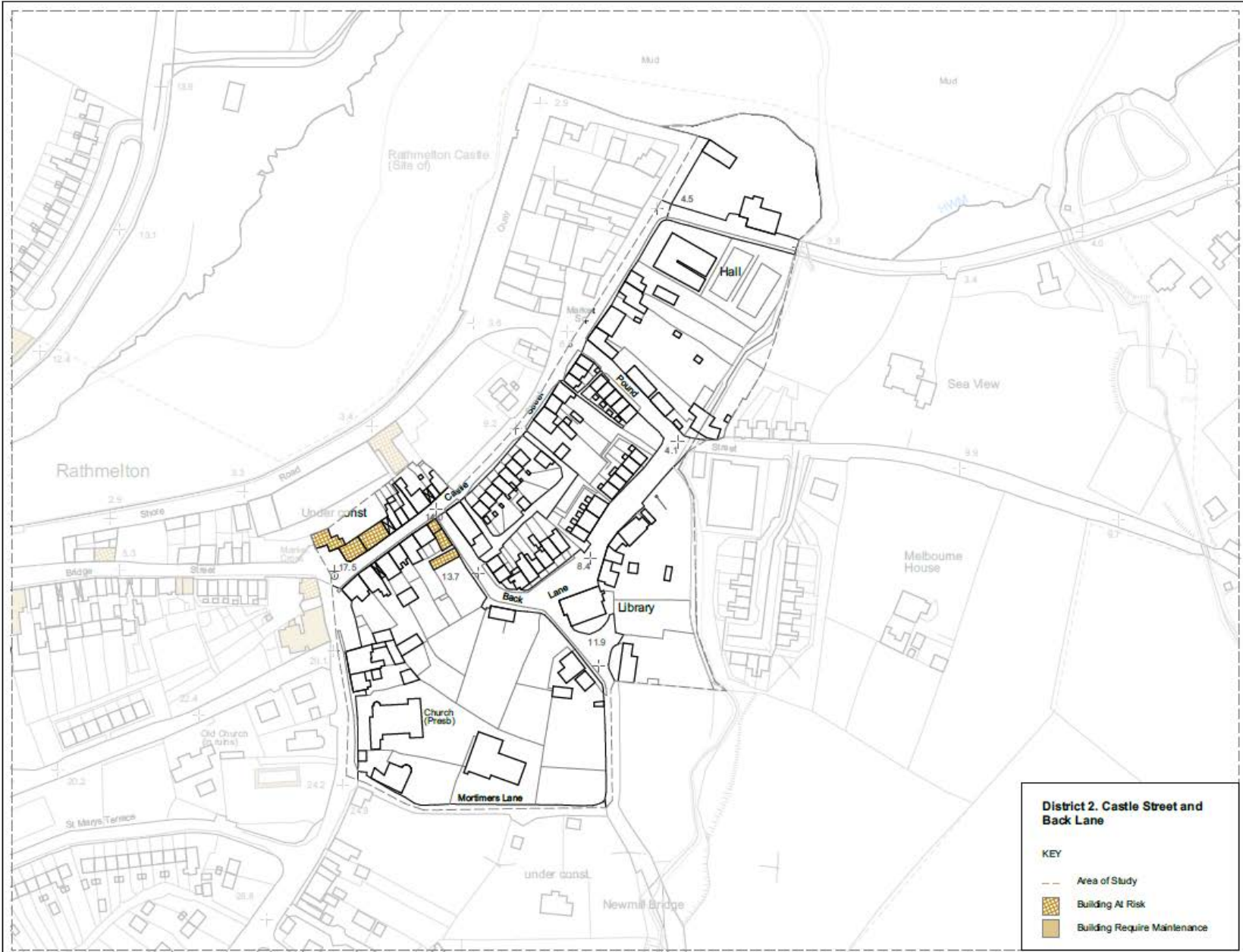

DEDALUS ARCHITECTURE
 Bath Terrace, Main Street, Moville, Co. Donegal
 Tel: +353 (0)749385122 Email: dedalusarchitecture@eircom.net

JOB No
00-542

The drawings copyright and property of Dedalus Architecture and are not to be reproduced or applied without the prior written permission of the author.

Rathmelton Regeneration Action Plan
Buildings at Risk - 2. Castle Street and Back Lane

Scale:
 1:2000
 Date:
 Sept 2018
 Drawn:
 EF

15



District 3. Church Street and Chapel Road

KEY

- Area of Study
- Building At Risk
- Building Require Maintenance

DEDALUS ARCHITECTURE
 Bath Terrace, Main Street, Moville, Co. Donegal
 Tel: +353 (0)749385122 Email: dedalusarchitecture@eircom.net

JOB No
00-542

The planning copyright and the project of this Action Plan are the property of DEDALUS ARCHITECTURE and shall be reproduced or used in any form without the prior written consent of the author.

Ramelton Regeneration Action Plan
Buildings at Risk - 3. Church Street and Chapel Road

Scale:
 1:2000
 Date:
 Sept 2018
 Drawn:
 EF

16

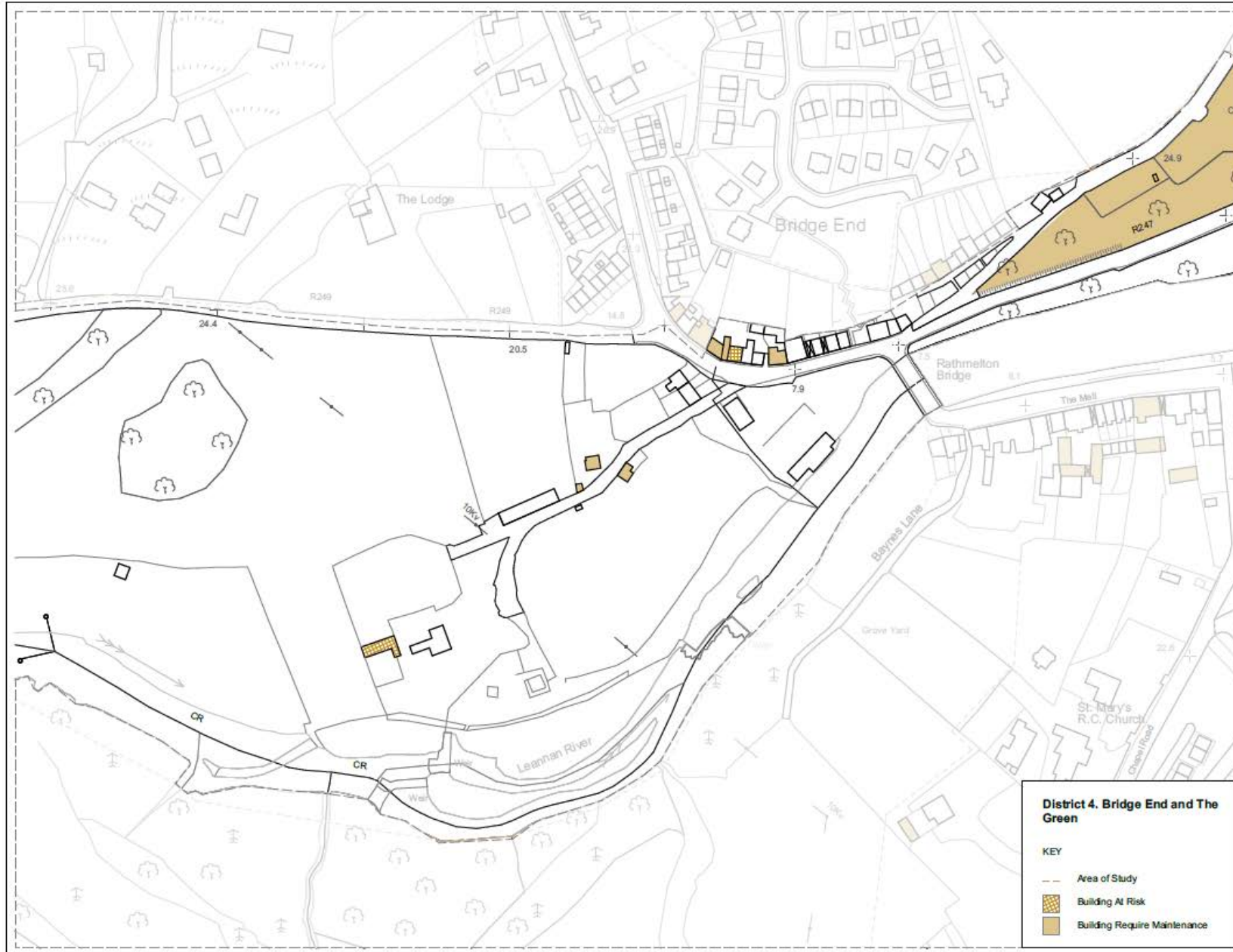

DEDALUS ARCHITECTURE
 Bath Terrace, Main Street, Moville, Co. Donegal
 Tel: +353 (0)749385122 Email: dedalusarchitecture@eircom.net

JOB No
00-542

This drawing is copyright and the property of Dedalus Architecture. It is to be used only for the project or projects to which it relates and no part of it may be reproduced without the prior written consent of Dedalus Architecture.

Ramelton Regeneration Action Plan
Buildings at Risk - 4. Bridge End and The Green

Scale:
 1:2000
 Date:
 Sept 2018
 Drawn:
 EF

17

Appendix – Environmental Action: Water Power & Electric Car Charging

Recent energy production figures for Ireland show that only 30% is currently generated from renewable resources.

According to “ChargeMap” there are currently 63 public electric car charging points in the whole of County Donegal. At time of writing 11% were out of order; 24% were in use and not available; 65% were available. There are no public charging points in Ramelton; the nearest in Letterkenny.

Several car manufacturers are moving to 100% electric car production before by 2025; many charging points will be needed. Climate Action Fund – ESB eCars high power charging infrastructure

In town centre locations, where only on-street parking is available, only fast charging points will be needed. This will require circa 30-40minutes to charge a car and public charging points will be in demand. Some demand will be met in garage forecourt locations although it is thought, for reasons of sustainability, some of the future demand may be met by carpooling or significantly improved public transport. Meeting car charging or transport needs will be a factor in choosing to live within the town centre in future and must be accommodated if the town is to survive.

Renewable Electricity Support Scheme (RESS) lock in prices for community power generation



There is an opportunity in Ramelton to Harness water power as a means of producing electricity locally.

Community power generation has potential to provide for a large portion of the electrical supply needs of Ramelton, as it has done so for other towns in Donegal in the past. Whilst outside the immediate scope of the study a technical study designed to develop a practical operational model is required to determine its feasibility.

The use of car charging points is likely to become more intensive in future & will require greater management. Where there is already public infrastructure committed to street lighting, the conversion of these positions to dual car charging and lighting points would prevent the proliferation of additional street furniture. Some customisation of standard fittings will also be required within historic townscapes so that their appearance integrates successfully with the environment.

¹ Ireland’s Transition to a Low Carbon Energy Future 2015-2030: Department of Communications Climate Action & the Environment

Appendix – Environmental Action: Waste Management

The basis for all waste management policy are the principles: “Reduce: Reuse: Recycle” and prevention before reuse of new resources. These principles apply particularly to historic building conservation and the reuse of old buildings will: 1) reduce the need for new building; 2) reuse existing buildings which already contain significant embodied energy; 3) any materials that are removed should be salvaged or recycled, ideally in the repair of the same building.

The continuing occupation of urban row houses on small sites within the town centre is an inherently efficient building form. However, for some properties, the lack of outside space can be problematic and communal recycling and composting schemes can make these more affordable homes also more habitable. In some cases more frequent refuse collection or shared waste storage or recycling facilities will be necessary as part of any proposals for refurbishment of the existing structures.

Imaginative proposals are needed to break current habits, such as the community-led free tap water scheme for reduction of plastic waste by encouraging people to refill reusable drinking water bottles.

In Kinsale a food festival prize is given for the best meal using only locally-sourced ingredients.

In Ramelton composted food and garden waste might be used as a mulch to improve soil for urban gardens.

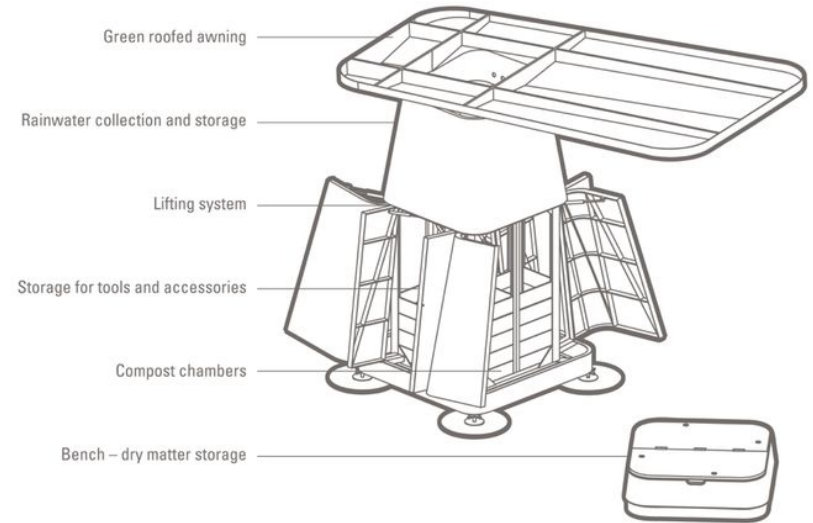

Sustainable street composter Nantes



Communal waste bin Brighton



Appendix – Environmental Action: Natural Heritage Alien Invasive Management

Two significant growths of Japanese Knotweed were observed in the survey, although both had been partially treated. These invasive plants can be associated with loss of diversity and, as well as spread by mechanical means, can also be spread by flooding.

The affected areas currently appear to be waste ground. The site to the rear of houses within the town centre, once treated, is potentially of use for allotments or as a community garden with access from the Market Cross.

Treatment of invasive plants requires special care and is reliant on careful timing. Both locations are close to the roadside and should be treated under the Donegal County Council Alien Plant Species Treatment Programme.



Appendix – Environmental Action: Natural Heritage Planting & Management of Habitats

There are several areas close to the town centre, which are relatively unused and provide refuge and foraging for bats, birds, insects and other wildlife safe from intensive agricultural practises. Local landowners are to be encouraged to manage these areas in a manner that maximises their ecological benefit.

Areas that have been identified as being suitable for guerilla gardens or temporary green spaces should be designed for their habitat and pollinator value as well as their potential for vegetable gardening.

Elsewhere, the River Leannan is highly protected and, where it passes through Ramelton, incorporates two Special Areas of Conservation and a Special Protection Area. Specific advice in connection with planting and habitat must take into account these protected sites and contribute to their continuing habitat value.

Community gardens for food and vegetables provides for a resilient, locally-grown food source, improvements to the local environment air quality and habitat, diet & general health & well-being for local people.

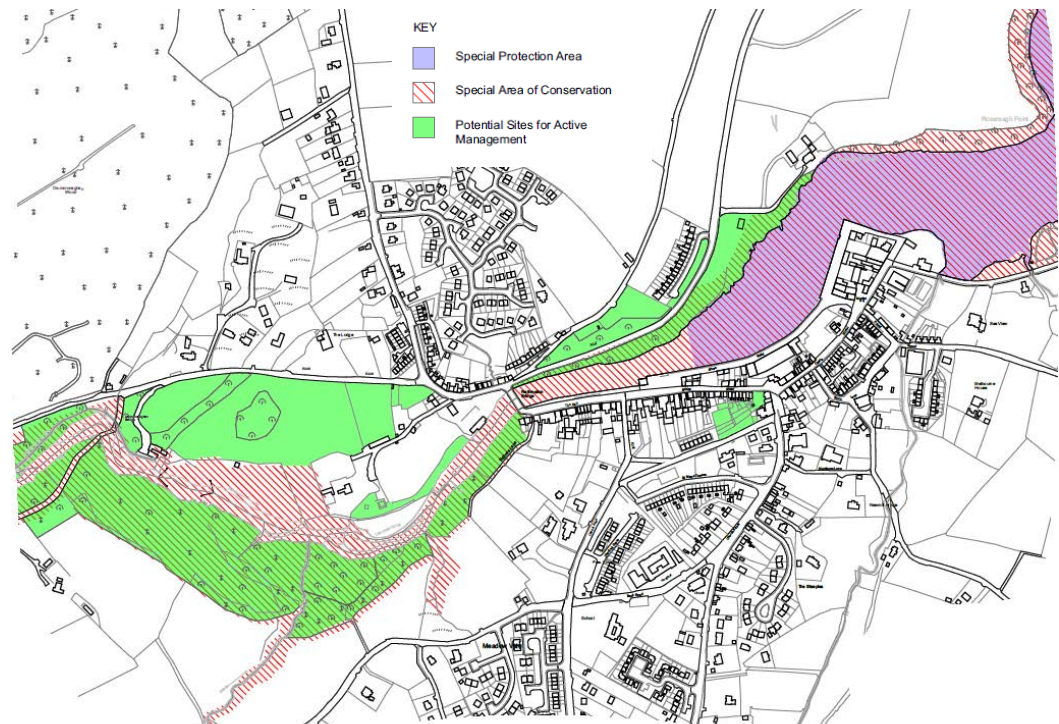
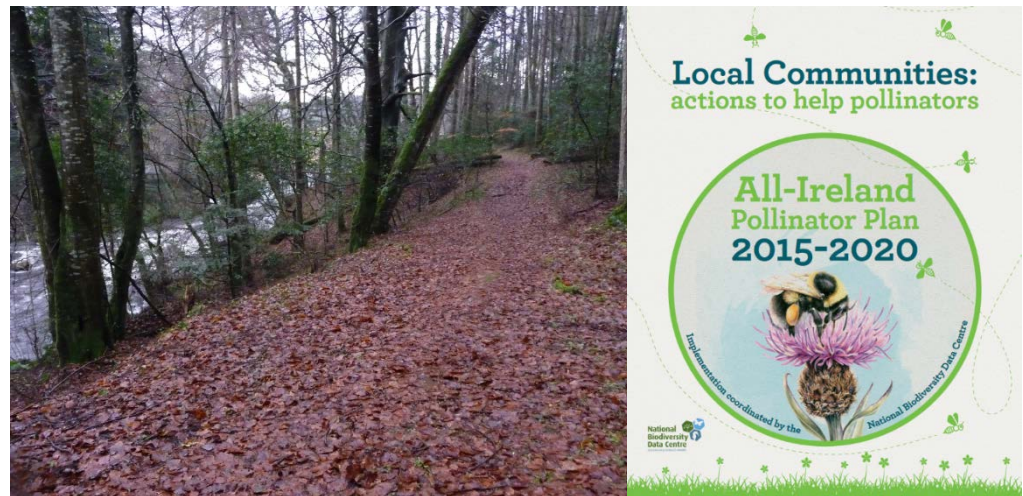

Appendix – Environmental Action: Rising Sea Levels, Rainfall Events & Flood Resilience

There have been a number of recorded historical flooding events in Ramelton, in 1995 and in 2014. Ramelton has been identified in the OPW Flood Risk Management Plan for the Northwest River Basin as an area for further assessment & a number of possible future measures identified. There are risks associated with tidal and fluvial flooding. As the effects of climate change have an impact, rising sea levels and extreme rainfall events will ensure that flooding will occur more frequently in future.

Whilst little can be done to prevent these events affecting the existing historic buildings, especially those around the quayside and mill race at the eastern, Lough Swilly, end of the town buildings that are to be repaired and conserved as part of the plan should be done so in a manner that will make them more resilient so that they can recover more quickly in the event that flooding does occur.

Measures might include installation of domestic flood barriers, using robust masonry finishes at ground floor level and installation of electrical fittings well above floor level. Active protection measures might also be used such as drainage maintenance, protection of drainage outlets from blockage, application of 'SUDS' to new proposals & landscape management upstream. Early warning measures in the form of text or mobile phone alerts might also be considered to provide warning to building owners where temporary flood barriers need to be fitted.



Appendix – Environmental Action: Ramelton “Transition Town”?

The actions that are proposed as a result of the analysis of the historic town fabric of Ramelton follow best conservation practise, however the application of these principles at a practical level will require the adoption and development of these principles by the wider community. It is proposed that the Transition Network provides a potential model to involve local people and provide the tools and inspiration that will be necessary for the successful implementation of this Action Plan.

“Transition is a movement that has been growing since 2005. It is about communities stepping up to address the big challenges they face by starting local. By coming together, they are able to crowd-source solutions. They seek to nurture a caring culture, one focused on supporting each other, both as groups or as wider communities.

In practice, they are reclaiming the economy, sparking entrepreneurship, reimagining work, reskilling themselves and weaving webs of connection and support. It’s an approach that has spread now to over 50 countries, in thousands of groups: in towns, villages, cities, Universities, schools.

Principles

Transition is an approach rooted in values and principles.

We respect resource limits and create resilience – The urgent need to reduce carbon dioxide emissions, greatly reduce our reliance on fossil fuels and make wise use of precious resources is at the forefront of everything we do.

We promote inclusivity and social justice – The most disadvantaged and powerless people in our societies are likely to be worst affected by rising fuel and food prices, resource shortages and extreme weather events. We want to increase the chances of all groups in society to live well, healthily and with sustainable livelihoods.

We adopt subsidiarity (self-organisation and decision making at the appropriate level) – The intention of the Transition model is not to centralise or control decision making, but rather to work with everyone so that it is practiced at the most appropriate, practical and empowering level



We pay attention to balance – In responding to urgent, global challenges, individuals and groups can end up feeling stressed, closed or driven rather than open, connected and creative. We create space for reflection, celebration and rest to balance the times when we’re busily getting things done. We explore different ways of working which engage our heads, hands and hearts and enable us to develop collaborative and trusting relationships.

We are part of an experimental, learning network – Transition is a real-life, real-time global social experiment. Being part of a network means we can create change more quickly and more effectively, drawing on each other’s experiences and insights. We want to acknowledge and learn from failure as well as success – if we’re going to be bold and find new ways of living and working, we won’t always get it right first time. We will be open about our processes and will actively seek and respond positively to feedback.

We freely share ideas and power – Transition is a grassroots movement, where ideas can be taken up rapidly, widely and effectively because each community takes ownership of the process themselves. Transition looks different in different places and we want to encourage rather than unhelpfully constrain that diversity.

We collaborate and look for synergies – The Transition approach is to work together as a community, unleashing our collective genius to have a greater impact together than we can as individuals. We will look for opportunities to build creative and powerful partnerships across and beyond the Transition movement and develop a collaborative culture, finding links between projects, creating open decision-making processes and designing events and activities that help people make connections.

We foster positive visioning and creativity – Our primary focus is not on being against things, but on developing and promoting positive possibilities. We believe in using creative ways to engage and involve people, encouraging them to imagine the future they want to inhabit. The generation of new stories is central to this visioning work, as is having fun and celebrating success.”

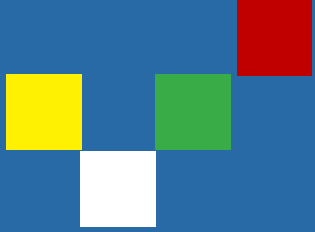

Rialtas na hÉireann
Government of Ireland

This project was funded by the
Department of Rural & Community Development
under the Town & Village Renewal Scheme

Dedalus Architecture •
Bath Terrace, Main Street,
Moyville, Co. Donegal

— July 2020 —



**Comhairle Contae
Dhún na nGall**
Donegal County Council