



Northern Periphery and
Arctic Programme
2014-2020



EUROPEAN UNION

Investing in your future
European Regional Development Fund

Errigal Path Report

Detailed Design of an Upland Path



Report Produced By: KLAND Ltd

Date of Report: 29th January 2019



Contents

1	Introduction	2
2	Design Considerations	2
3	Survey Methodology	3
4	Survey Findings	3
5	Maintenance	8
6	Section 1: The Peat Path	9
7	Section 2: The Rib	22
8	Section 3: The Stone Path	24
9	Section 4: Summit Ridge	31
10	Materials	33
11	Method Statements	35
Appendices	Path Specifications	40

1. Introduction

KLAND Ltd has been commissioned by Donegal County Council to carry out detailed path specification surveys on the 'Stream Route' on Errigal, as part of the EU INTERREG funded ASCENT project. This is following on from earlier consultation work on route selection carried out by *Walking The Talk* on behalf of the Council, culminating in the Errigal Mountain Path Study Report completed in 2015.

The 'Stream Route' was selected in the Mountain Path Study, and this will take users onto the eastern bank of the river, and away from the steep and badly eroded path that most users currently access and egress Errigal.

As part of this report the following has been provided:

- Detailed maps showing the proposed route which has been surveyed, including the 4 clear sections requiring different techniques and the GPS points where each part of the survey starts and ends.
- Detailed 'Red' Specification Survey sheets showing each section with present condition along with what works are required to make the route suitable for use
- Images of the route to highlight sections of interest or areas requiring greater attention
- Detailed design specifications of each proposed building technique/specific feature

2. Design Considerations

The path is within the Cloghernagore Bog and Glenveagh National Park Special Area of Conservation, and the Derryveagh and Glendowan Mountains Special Protection Area, and as such sensitivity to environment is paramount for path design. Once built the path itself will help the damaged ground repair by concentrating use on a sustainable upland path line, but it is important that construction techniques will not have a detrimental effect on the conservation or landscape values of the site. The route passes through a rugged and wild landscape and so the

line selected and techniques recommended needed to reflect these qualities and to minimise visual impact.

The route also needed to carefully consider Land Management requirements with the hill used for livestock grazing by the landowners with commonage rights.

The hill is experiencing growing visitor numbers from a wide spectrum of users. Experienced hill walkers do use the path, but so too do poorly shod and inexperienced walkers visiting the area, with information gleaned from TripAdvisor rather than mountaineering publications.

The 'Stream Path' choice represents a significant realignment from the route most people use, and is longer than the currently used route. However sensitive habitats highlighted by the project's ecologist as becoming increasingly damaged through wear and tear by walkers will be avoided. It also takes people away from the direct line of sight of their vehicle in the car park as they come off the mountain. Making the route work will require very careful alignment between sections 2 and 3, in tandem with quality visitor information to explain the need for the new line, and the benefits to the public in terms of quality of experience the new route will offer.

3. Survey Methodology

A survey of the proposed work items was carried out using equipment including a clinometer, ranging pole, measuring wheel, tape measure, GPS and camera to record factors including slope, distance and route which were used to draw up a specification for the works.

The surveys are included in each section and the line has been shown as a straight line for simplicity with proposed works and distance (in metres) from the start of the path given.

Photographs were taken along the length of the proposed path and show the route with the specific work items identified.

4. Survey Findings

The surveyed route follows the stream on the East bank until it joins up with the Northern approach and takes a very rugged but very robust route ascending to the large cairn on the main route. From here the path is back onto the most popular, and most damaged line where it ascends to the summit ridge, and then traverses along the ridge eventually reaching the summit at 751m OD. It makes sense to look at the path in 4 distinct phases, each with different treatment required:

- **Section 1, The Peat Path (0 – 1280m Chainage):** The surveyed route moves all hill users onto the East side of the stream for the first section and the first 720m is on badly eroded peat bog, and is very wet, with up to 30 metres wide path spread in places as walkers try to avoid the worst parts. Beyond this the path remains on peat, but the route is currently lightly used and the path somewhat drier at present, though this would break down rapidly with increased use without a constructed path. There are two short sections that will require board walk, to reduce the impact of the habitat due to the complexity of terrain, though the rest of the route can be treated with floated aggregate path on geotextiles and effective drainage systems that protect the path without altering the hydrology of the bog. This will need full build construction and will require planning permission.
- **Section 2, The Rib (1280m to 1871m Chainage) :** At the top of the Peat Path, the route turns into the mountain on an exposed rib on shallow, shattered bedrock. This is a very robust route, and requires minor light touch works only to offer a narrower unconstructed route, and effective alignment. The work will involve minor landscaping
- **Section 3, The Stone Path (1871m to 2404m Chainage):** At the top of 'The Rib' the route goes back onto the main desire line for Errigal and is on very steep and badly eroded quartzite scree. The erosion scar is very wide in places and is highly dynamic. Without intervention the route will continue to widen, and the erosion spread and deepen. The solution here is stone pitching supported with revetment, to provide a highly robust steep path that users will stick to allowing the surrounding area to naturally regenerate and stabilise.

- ***Section 4, Summit Approach (2404m to 2824m Chainage):*** As the path gets closer to the summit, the steepness of slope recedes, and the route goes through bands or outcrop and along an exposed ridge. The path does not require formal construction, but there are multiple routes along the ridge, and light touch works to align the path onto a single line would do a lot to help stabilise erosion, narrow the corridor of use, and allow natural regeneration on the sensitive habitat on the north side of the ridge.

Post project management of the realigned path will be very important once work is complete, and key tasks in the success of the route will be encouraging users to stay on the East bank of the stream on the way up, and to take the robust rib down on the descent, rather than going straight down the eroded part of the hill to the car park as most walkers currently do. Alignment on the join between section 2 , The Rib, and Section 3, The Stone Path will be vital, and visitor information explaining the need to protect the habitat on the one hand, and the quality of experience offered by the new route will be vital to the ongoing management of the route once complete.

Errigal Path Map

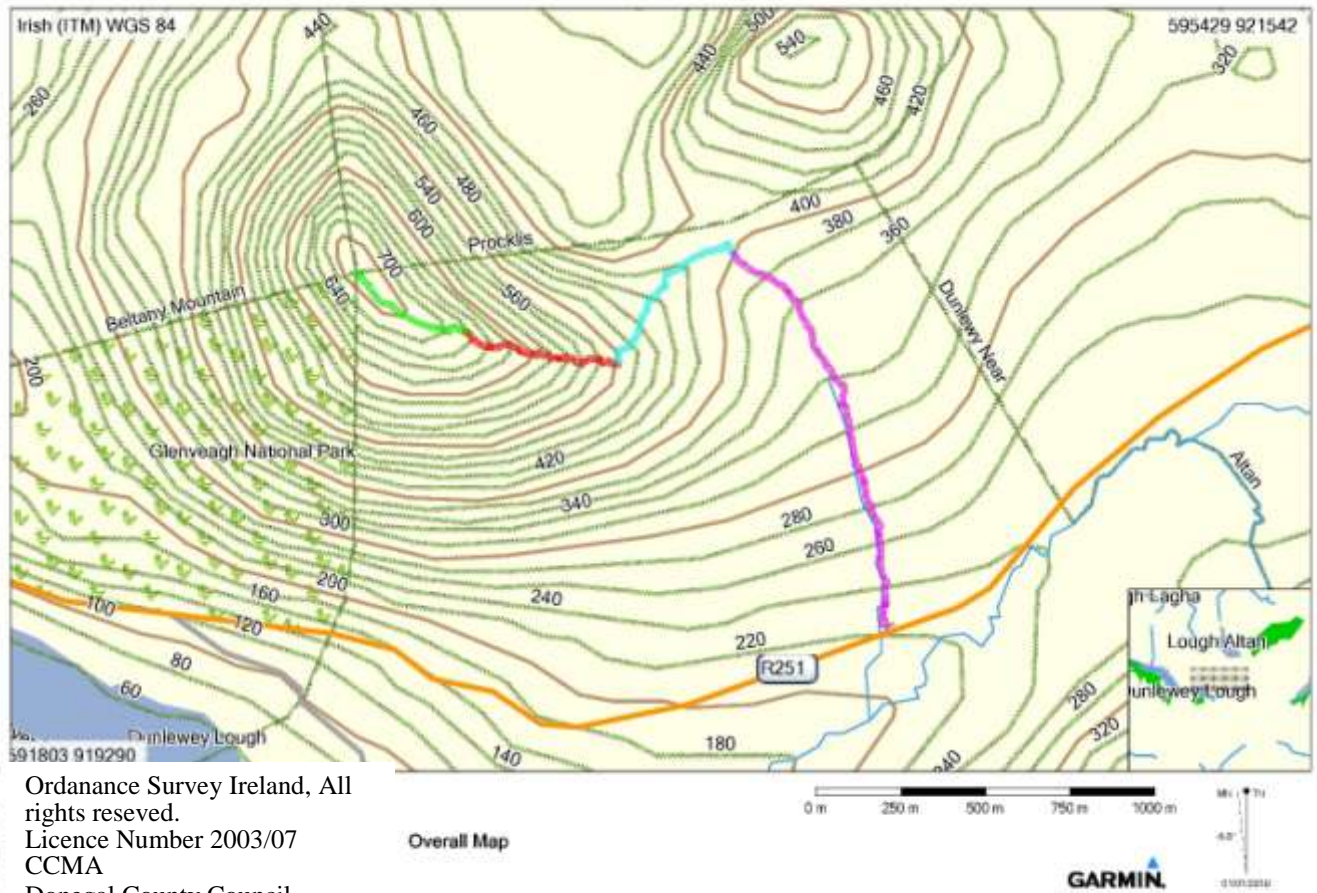

-  Section 1 - The Peat Path
-  Section 2 The Rib
-  Section 3 The Stone Path
-  Section 4 Summit Approach

5. Maintenance

The Section 1 Peat Path will need to have regular runs to clean out the silt traps and replace surfacing. Stone features should be checked periodically, and any damage or loose stones made good. The Board Walk should be inspected annually, and decking replaced as necessary.

Section 2 The Rib should be adjusted annually with the defined line cleared of loose debris, and any developing shortcuts or braid lines blocked off.

Section 3 The Stone Path is a very robust line but should be checked annually and any loose or damaged stones should be made good. The ground on either side of the path should be checked and if necessary blocking works included to prevent people from shortcutting.

Section 4 The Summit Approach will need to be checked annually and loose debris removed from the path line. Any emerging shortcuts or new braid lines should be blocked off using weathered stone and any available sod.

6. Section 1: The Peat Path (0 – 1280m Chainage)

The Peat Path

Section 1, the 'Peat Path' is very wet and badly eroded and will need to be floated on geotextiles and built with aggregate predominantly. The path will need to be raised above the surrounding bog, and the drains countersunk so as to avoid flooding of the path, whilst allowing free movement of the water from one side of the path to the other without unnecessarily draining the surrounding habitat. Heavy sods will need to be transplanted from the damaged zone to make a path edge, and the aggregate Type 1 (40mm down) will need to be imported from a quarry with material sympathetic to the landscape and chemical composition of the habitat. Care will need to be taken at all times to ensure silt is prevented from entering the stream from the exit points on the drainage features.



The path will require locally sourced or indigenous aggregate to be flown up from the car park, as use of machinery is not allowed on the site. The water management features including cross drains, water bar and revetment will require imported construction stone to give the path a mountain path style, and it is recommended that this is sourced from the surrounding hill and comprises weathered quartzite rocks to best blend in with the surrounding environment.

The drainage features will need to be built in a way to ensure that peat is not eroded at the inlet and outlets where water flow is concentrated and use of splash plates built of stone will be required for this. The path runs in close proximity to the stream for most of the route and use of stone-built silt traps will need to be utilised to prevent leached through path fines from entering the water course.



Example of raised aggregate path in upland blanket bog in Scotland



Example of Recycled Plastic Boardwalk

Map Of Section 1 = The Peat Path

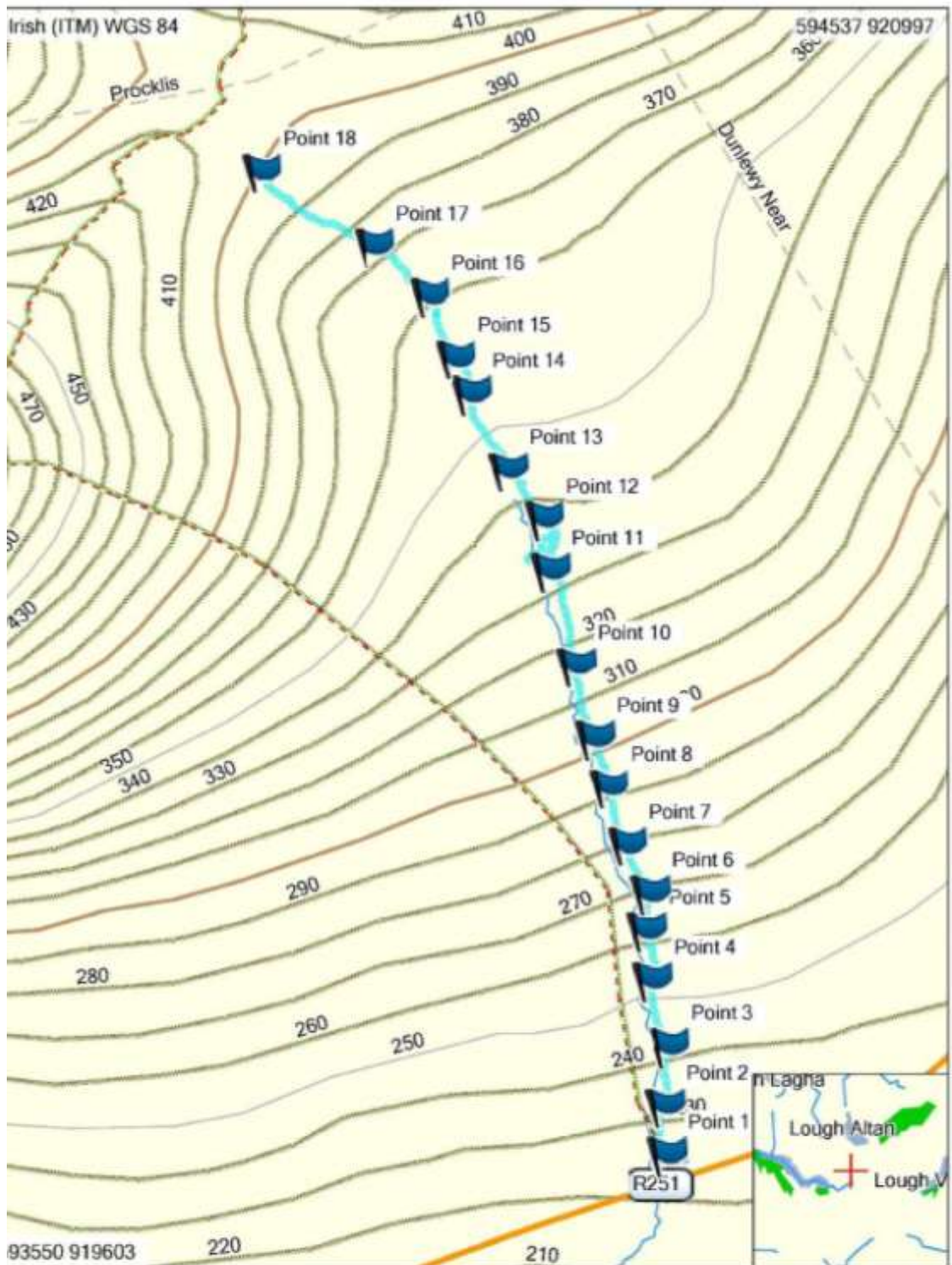

Ordnance Survey Ireland,
 All rights reserved.
 Licence Number 2003/07
 CCMA
 Donegal County Council

1. Peat Path



Section 1 Bill Of Quantities





ITEM	WORKS DESCRIPTION	UNIT	QTY
1	Full Build Aggregate Path 1: Using as-dug materials as generated during top-side-ditching lay aggregate path, 1050mm to 1200mm variable width / 250mm with 100mm countersunk and 150mm raised Type 1 - 40mm down quartz based aggregate (1:50 camber) fines top coat, on top of T1000 fabric and Tensar GeoGrid. Compact to submission. Landscape spoil and form edges.	m	720
2	Full Build Aggregate Path 2: Using as-dug materials as generated during top-side-ditching lay aggregate path, 900mm to 1050mm variable width / 250mm with 100mm countersunk and 150mm raised Type 1 - 40mm down quartz based aggregate (1:50 camber), on top of Terram T1000 fabric and Tensar GeoGrid. Compact to submission. (1:50 camber) Landscape spoil and form edges	m	475
3	Anchor Bars: Construct stone built anchor bars, using on-site rock across the full path width. To extend 150mm either side of the path edge and be flush with the path surface. The stone will form an independent structure to reinforce the aggregate of the path and pressure of use. Only weathered tops are to be visible.	each	34
4	Water Bars: Using on site stone, construct water/detritus shedding bars;. between 30°- 45° to the path line. Bar depth should be a minimum of 100mm rising to approximately 150mm but not be obstructive. Liner should provide a draining fall of 5° minimum. Extend by 300mm on each path side. No gaps between bar stones.	each	47
5	Stone Cross Drains: Using on site stone, construct stone cross drain with good treads which will lie flush with path surface. No gaps in side walls, minimum channel depth 300mm. Stone lined with shedding gradient of 5° minimum. Fully extended off either side of the path (min 300mm off-path) Provide outflow channel approximately 5m.	each	32
6	Top Side Ditch: Side Drain should be up to 300mm wide, concave and up to 300mm deep. Drain will be fully landscaped. See UPAG Manual.	m	1195
7	Board Walk: Provide raised board walk using recycled (detailed specification attached)	m	25
8	Pitching: Construct rock / boulder pitched path to a variable width between 850 to 1050mm. Irregular, random treads must be comfortable to use over an even gradient. Maximum riser height to be 150mm (6 inches). The construction must be solid with stones fitting tightly, well packed, with overlapping joints. Use excavated sods, spoil and boulders to define and contain the path edge. Rock to be well set into the ground at least 300mm with a level treading surface.	m	30
9	Revetment Construct retaining revetment wall to stabilise the slope below path. The construction must be solid and stable, with large foundation stones, off-set joints, pinned and backfilled firmly. Pack gaps between the courses with sod and fully landscape. See UPAG Manual.	m	45

Tonnage of Aggregate required = 600 Tonnes, Tonnage of Construction Rock = 80 Tonnes

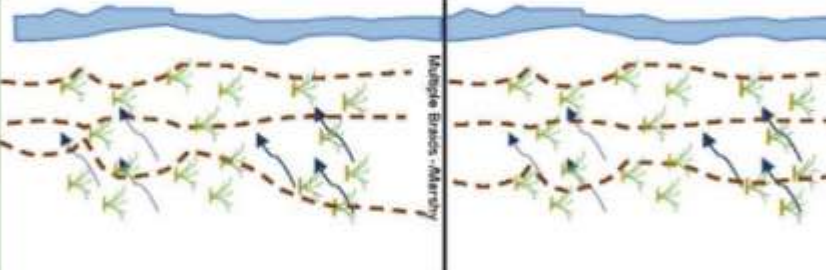
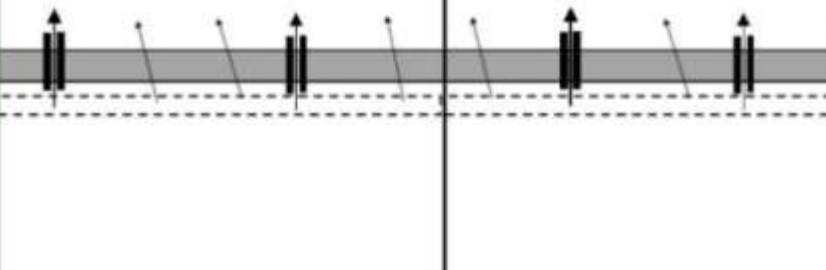
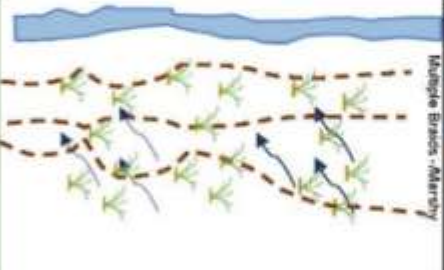
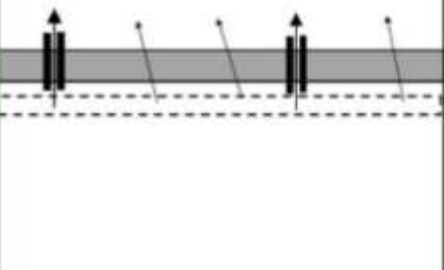

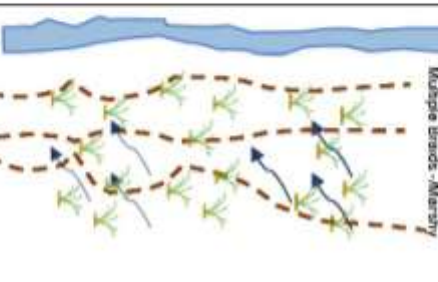
Total of 680 helicopter runs required with single engine Eurocopter AS350 Ecureuils or equivalent

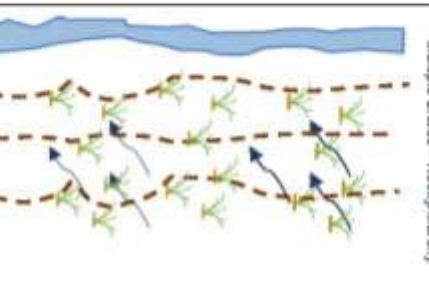
'Peat Path' Specification Survey (0 – 1280m Chainage)

Point/gm	Existing Path & Features	Avg Peak Depth	P.W. (m)	Work Required	Description
Point 2 504241 TM919780		600mm	1050mm - 1200mm		<p>60m Aggregate Path</p> <p>Using imported materials, construct a (using Geotextiles: T1000 Terram and throughout), 1050mm-1200mm width depth Type 1 surfacing Compact to s</p> <p>Install 2 no Anchor Bars</p> <p>Install 3 no Water Bars</p> <p>Install 2 no Cross Drains</p> <p>Install 70m Top Side Ditch</p> <p>Landscaping using turves (sods) with zone</p>
Point 1 504242 TM919225		500mm	1050mm - 1200mm		<p>60m Aggregate Path</p> <p>Using imported materials, construct a (using Geotextiles: T1000 Terram and throughout), 1050mm-1200mm width depth Type 1 surfacing Compact to s</p> <p>Install 2 no Anchor Bars</p> <p>Install 3 no Water Bars</p> <p>Install 2 no Cross Drains</p> <p>Install 60m Top Side Ditch</p> <p>Landscaping using turves (sods) with zone</p>
	Section 1 Start Start of CA Path 504241 TM919225	9"			

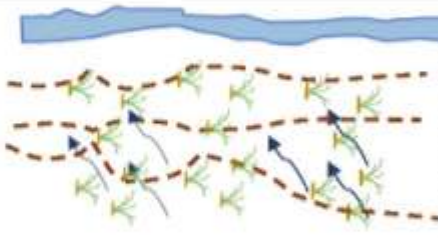
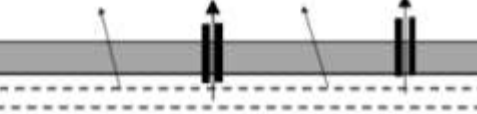
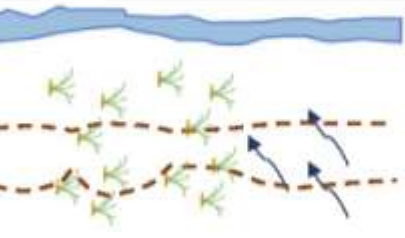
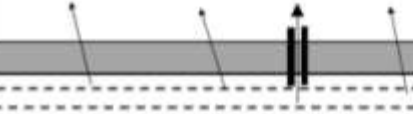
Existing Path & Features	Peat Depth	P.W. (m)	Work Required	Description
 <p>Multiple Brands - Maratry</p>	716mm	1050mm - 1200mm		<p>70m Aggregate Path Using imported materials, cor (using Geotextiles: T1000 Tel throughout), 1050mm-1200m depth Type 1 surfacing. Corn]</p> <p>Install 2 no Anchor Bars</p> <p>Install 3 no Water Bars</p> <p>Install 2 no Cross Drains</p> <p>Install 70m Top Side Ditch</p> <p>Landscaping using turves (so zone</p>
 <p>Multiple Brands - Rocky/Marariv</p>	700mm	1050mm - 1200mm		<p>70m Aggregate Path Using imported materials, cor (using Geotextiles: T1000 Tel throughout), 1050mm-1200m depth Type 1 surfacing. Corn]</p> <p>Install 2 no Anchor Bars</p> <p>Install 3 no Water Bars</p> <p>Install 2 no Cross Drains</p> <p>Install 70m Top Side Ditch</p> <p>Landscaping using turves (so zone</p>

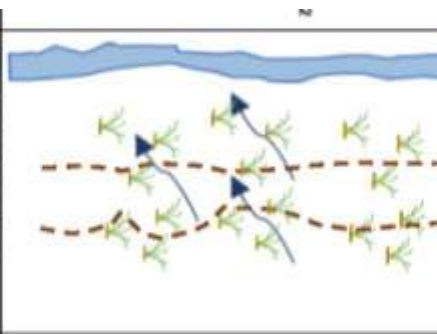
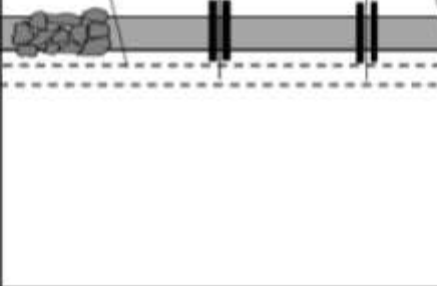
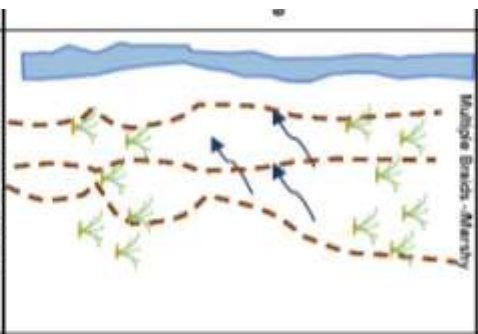
Existing Path & Features	Pave Depth	P.M. (m)	Work Required	Description
 <p>Multiple Bars - Peat Traps</p>	800mm	1050mm - 1200mm		<p>50m Aggregate Path Using imported materials, construct (using Geotextiles: T1000 Terrar throughout), 1050mm-1200mm width depth Type 1 surfacing Compact</p> <p>Install 2 no Anchor Bars</p> <p>Install 2 no Water Bars</p> <p>Install 2 no Cross Drains</p> <p>Install 50m Top Side Ditch</p> <p>Landscaping using turves (sods) zone</p>
	800mm	1050mm - 1200mm		<p>Using imported materials, construct (using Geotextiles: T1000 Terrar throughout), 1050mm-1200mm width depth Type 1 surfacing Compact</p> <p>Install 2 no Anchor Bars</p> <p>Install 2 no Water Bars</p> <p>Install 1 no Cross Drain</p> <p>Install 60m Top Side Ditch</p> <p>Landscaping using turves (sods) zone</p>

Existing Path & Features	Peak Depth	P.W. (m)	Work Required	Description
 <p>Multiple Branch - Many</p>	1000mm	1050mm - 1200mm		<p>(using Geotextiles: 11000 Terrain throughout), 1050mm-1200mm v depth Type 1 surfacing. Compact</p> <p>Install 2 no Anchor Bars</p> <p>Install 2 no Water Bars</p> <p>Install 2 no Cross Drains</p> <p>Install 50m Top Side Ditch</p> <p>Install 10m Stone Pitching</p> <p>Landscaping using turves (sods) zone</p>
 <p>Multiple Branch - Many</p>	960mm	1050mm - 1200mm		<p>80m Aggregate Path</p> <p>Using imported materials, constr (using Geotextiles: T1000 Terrain throughout), 1050mm-1200mm v depth Type 1 surfacing. Compact</p> <p>Install 2 no Anchor Bars</p> <p>Install 2 no Water Bars</p> <p>Install 2 no Cross Drains</p> <p>Install 80m Top Side Ditch</p> <p>Landscaping using turves (sods) zone</p>

2e, G = Gradient, P.W.= Path Width

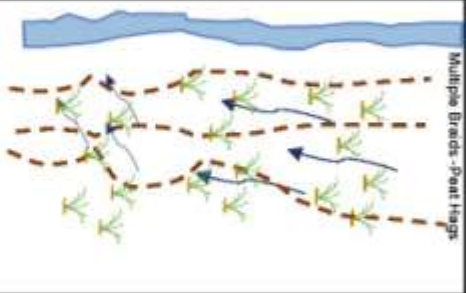
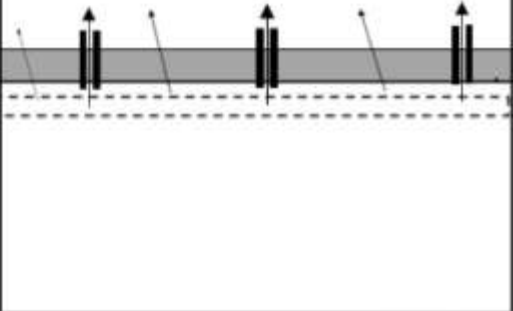
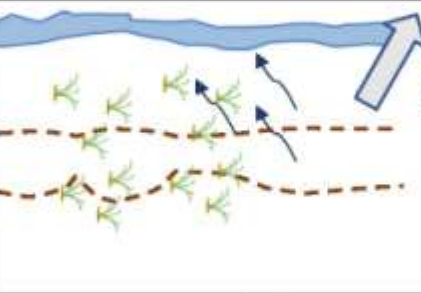
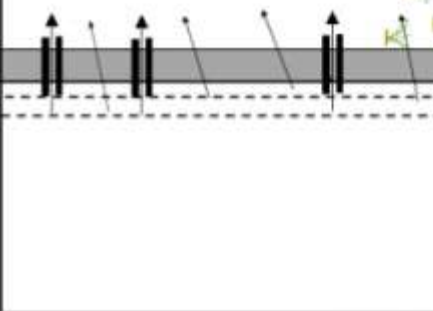
Existing Path & Features	Post Depth	P.W. (m)	Work Required	Description
	900mm	1050mm - 1200mm		<p>90m Aggregate Path</p> <p>Using imported materials, construct (using Geotextiles: T1000 Terram; throughout), 1050mm-1200mm w/c depth Type 1 surfacing. Compact 1</p> <p>Install 2. no Anchor Bars</p> <p>Install 3. no Water Bars</p> <p>Install 3. no Cross Drains</p> <p>Install 90m Top Side Ditch</p>
	1000m	1050mm - 1200mm		<p>Using imported materials, construct (using Geotextiles: T1000 Terram; throughout), 1050mm-1200mm w/c depth Type 1 surfacing. Compact 1</p> <p>Install 3. no Anchor Bars</p> <p>Install 4. no Water Bars</p> <p>Install 3. no Cross Drain</p> <p>Install 120m Top Side Ditch</p>

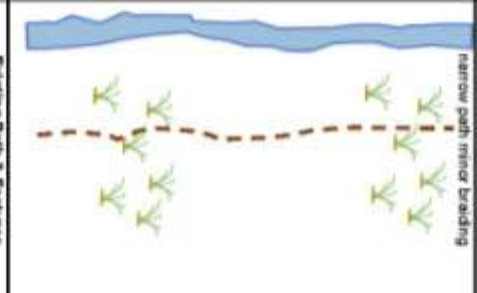
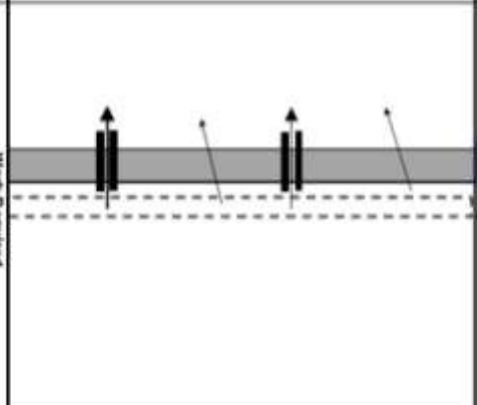
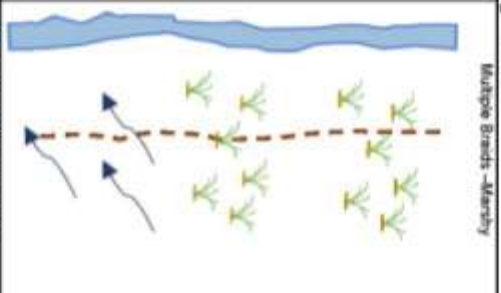
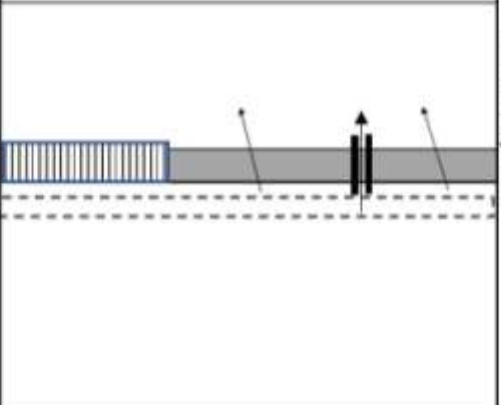
ID/Ref	Existing Path & Features	D1	P.M. (mm)	Work Required	Detail
Int 12 4116 R20429	 <p>narrow path minor branching</p>	850mm	900mm-1050mm		50m Aggregate Path Using imported materials, c (using Geotextiles: T1000 T throughout), 900mm-1050m Type 1 surfacing. Compact Install 2. no Anchor Bars Install 2. no Water Bars Install 1. no Cross Drain Install 50m Top Side Ditch Install 10m Boardwalk
Int 11 4122 R20422		850mm	900mm-1050mm		80m Aggregate Path Using imported materials, c (using Geotextiles: T1000 T throughout), 900mm-1050m Type 1 surfacing. Compact Install 2. no Anchor Bars Install 2. no Water Bars Install 2. no Cross Drains Install 80m Top Side Ditch

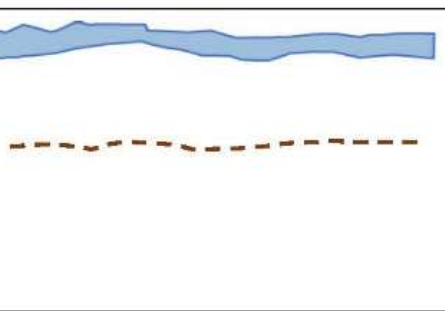
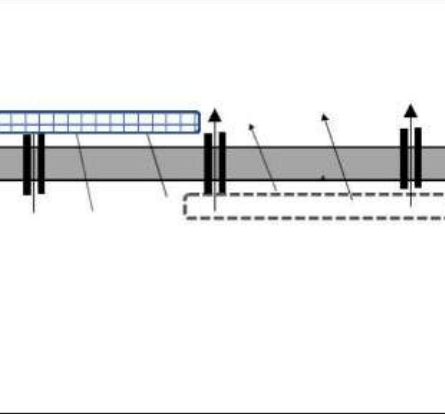
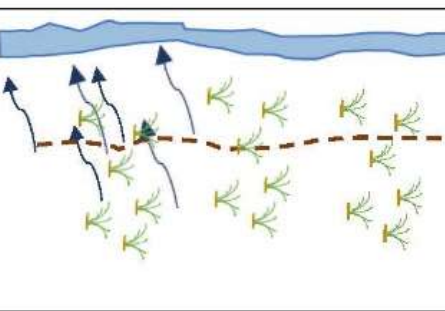
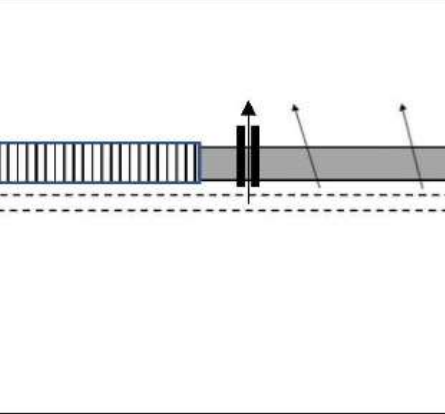
jm	Existing Path & Features	G(°)	P.W. (m)	Work Required	Descriptio
14 10 568		350mm	900mm-1050mm		<p>100m Aggregate Path Using imported materials, con (using Geotextiles: T1000 Ter throughout), 900mm-1050mm Type 1 surfacing: Compact to</p> <ul style="list-style-type: none"> Install 3. no Anchor Bars Install 4. no Water Bars Install 3. no Cross Drain Install 100m Top Side Ditch Install 45m Revettment
13 9 484		1100m	900mm-1050mm		<p>35m Aggregate Path Using imported materials, con (using Geotextiles: T1000 Ter throughout), 1050mm-1200mm Type 1 surfacing: Compact to</p> <ul style="list-style-type: none"> Install 2. no Anchor Bars Install 2. no Water Bars Install 1. no Cross Drain Install 35m Top Side Ditch Install 15m Boardwalk

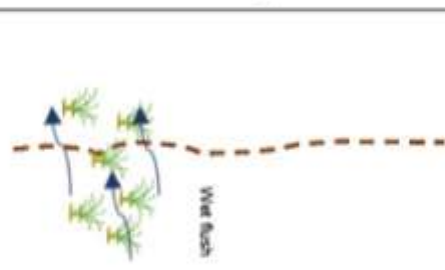
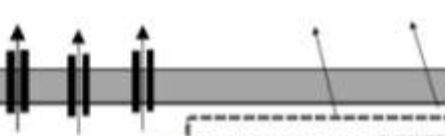
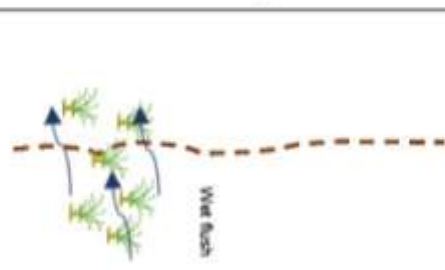
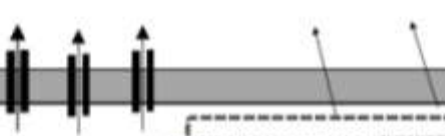
pm	Existing Path & Features	Peat Depth	P.W. (m)	Work Required	Description
16 10 675		450mm	900mm-1050mm		<p>Using imported materials, cons (using Geotextiles: T1000 Terr throughout), 900mm-1050mm Type 1 surfacing. Compact to 4</p> <p>Install 3, no Water Bars</p> <p>Install 1, no Cross Drain</p> <p>Install 90m Top Side Ditch</p> <p>Install 20m Stone Pitching</p>
15 14 607		900mm	900mm-1050mm		<p>70m Aggregate Path</p> <p>Using imported materials, cons (using Geotextiles: T1000 Terr throughout), 900mm-1050mm Type 1 surfacing. Compact to 4</p> <p>Install 2, no Anchor Bars</p> <p>Install 2, no Water Bars</p> <p>Install 3, no Cross Drains</p> <p>Install 50m Top Side Ditch</p>

inoc; G = Gradient, P.W= Path Width

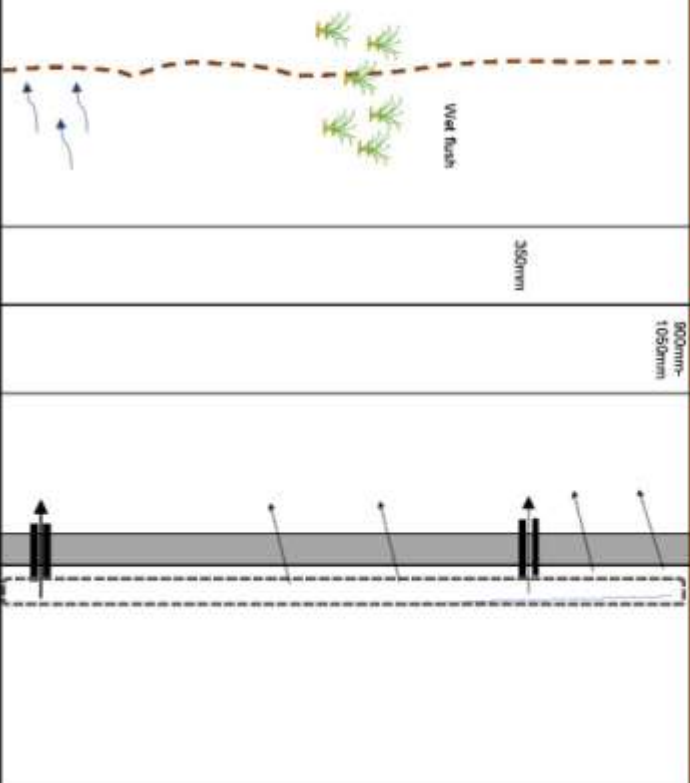
ite	Hand Build		Survey Sheet M
Work Required			
<p>End of Survey Upgrade Path to the Bus SHEET 11M20114</p> 	<p>900mm- 1050mm</p>	<p>12m Aggregate Path Using imported mater (using Geotextiles: T1 throughout), 900mm- Type 1 surfacing. Cor</p> <p>Install 3 no Anchor Ba Install 4 no Water Bar Install 2 no Cross Dra Install 120m Top Side</p>	

7. Section 2: The Rib (1280m to 1871m Chainage)

Section 2 is a rib of robust ground with thin soil and vegetation on a boulder scree and shattered quartzite bedrock. The line is currently used primarily by walkers coming from the Lough Altan direction, to the North, which is promoted in some mountaineering publications. The ground on this section is highly resistant to damage and could easily absorb a significant increase on user numbers. It will be important to prevent path spread however, and the key to this is path alignment utilising 'light touch' techniques



Section 2, The Rib: A robust path on the traditional northern approach to Errigal

A method statement for light touch works is included within the appendices. For Section 2 work will be focussed on alignment onto a single route, de-roughening of the path walkers are encouraged to use, and roughening and blocking where necessary to reduce the likelihood of path spread.

Map Of Section 2 The Rib

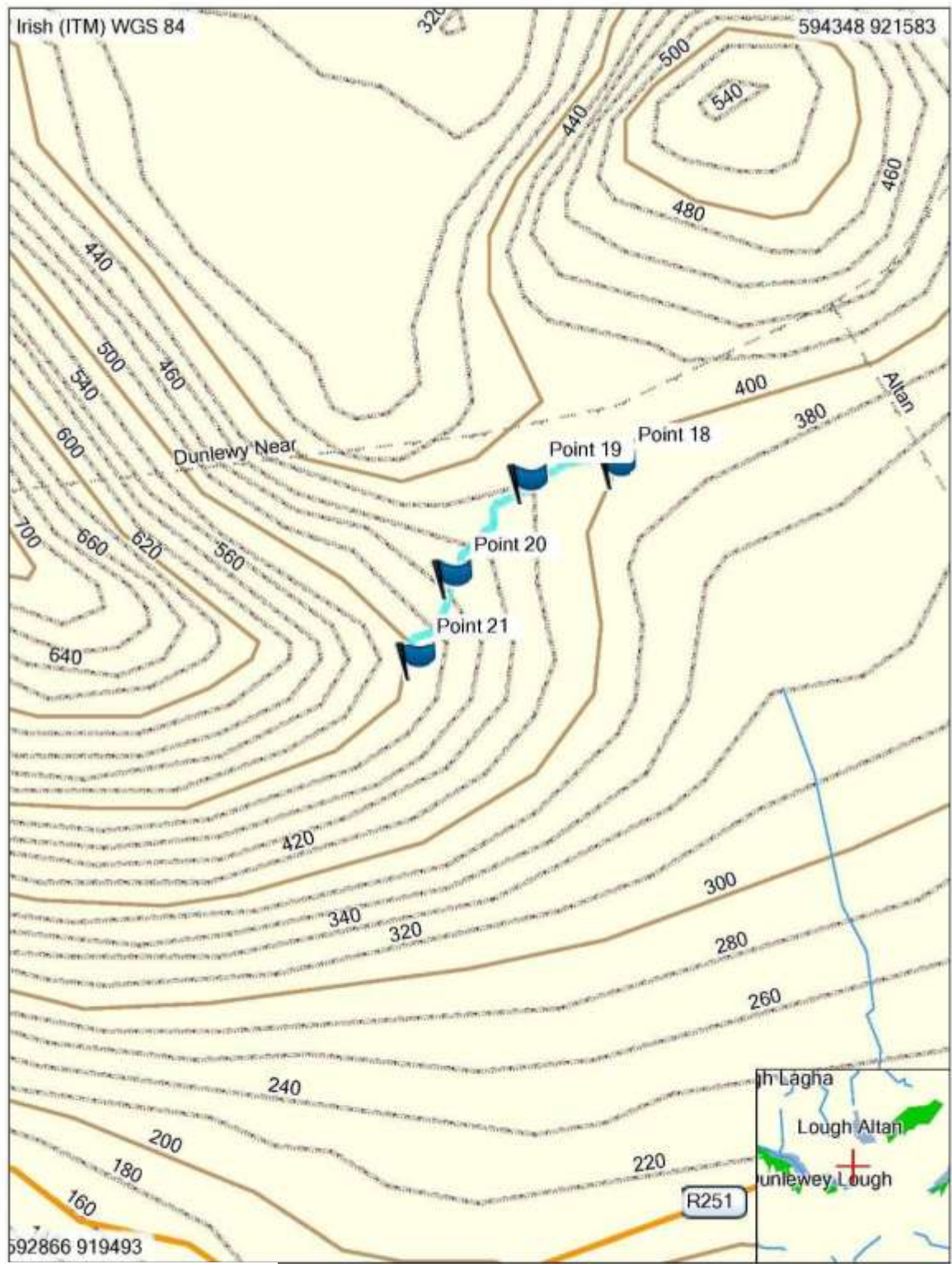

Ordnance Survey Ireland,
All rights reserved.
Licence Number 2003/07
CCMA
Donegal County Council

2. The Rib

0 m 150 m 300 m 450 m 600 m
MI 1:25000
-5.8°
GARMIN
01/01/2010

8. Section 3: The Stone Path (1871m to 2404m Chainage)

Section 3, the Stone Path, runs from the large hollowed out cairn up towards the top of the ridge, and has the worst erosion on the hill, in terms of material loss. The terrain is steep, the quartzite scree loose, and a wide scar has developed as walkers try to find the least uncomfortable line to get up and down the slope. In places the material has been lost down to bedrock, and you can see exposed sections. The site is highly dynamic, and prone to widening and deepening of the erosion scar.



Erosion on the Stone Path is in places down to the bedrock, and is liable to further widening and deepening without intervention.

The solution to the site will need to be a highly robust path, that can hold on steep ground, and fits in with the high landscape qualities of the upper mountain. The best option is stone pitching to provide a strong surface, with revetment edge to protect the edge of the path.

There is abundant weathered quartzite available across the hill, though material of a suitable size for most of the route this will need to be bagged by hand, and transported the short distance across the hill by helicopter. Weathered quartzite will provide a path in keeping with the surroundings and geology of the hill, and the weathered stone will tone down the visual impact as well as giving the whole path a much more natural, and 'old' look.



Weathered quartzite stone pitching on Sliabh Liag, Co Donegal. The path looks natural and 'old,' and very much in keeping with the surroundings

Section 3 The Stone Path Map



Ordnance Survey Ireland,
All rights reserved.
Licence Number 2003/07
CCMA
Donegal County Council

3. Stone Path



Section 3 The Stone Path - Bill Of Quantities

ITEM	WORKS DESCRIPTION	UNIT	QTY
1	Water Bars: Using on site stone, construct water/detritus shedding bars; between 30°- 45° to the path line. Bar depth should be a minimum of 100mm rising to approximately 150mm but not be obstructive. Liner should provide a draining fall of 5° minimum. Extend by 300mm on each path side. No gaps between bar stones. See UPAG Manual.	each	21
	Landscaping: Define line, use available sods and scree to prepare the ground outside the path edges for natural regeneration	sq m	500
3	Pitching: Construct rock / boulder pitched path to a variable width between 850 to 1050mm. Irregular, random treads must be comfortable to use over an even gradient. Maximum riser height to be 150mm (6 inches). The construction must be solid with stones fitting tightly, well packed, with overlapping joints. Use excavated turfs, spoil and boulders to define and contain the path edge. Rock to be well set into the ground at least 300mm with a level treading surface. See UPAG Manual.	m	533
4	Revetment Construct retaining revetment wall to stabilise the slope below path. The construction must be solid and stable, with large foundation stones, off-set joints, pinned and backfilled firmly. Pack gaps between the courses with turf and fully landscape. See UPAG Manual.	m	533

Tonnage of Stone Required for construction = 450 Tonnes

Total of 450 helicopter runs required with single engine Eurocopter AS350 Ecureuils or equivalent

Section 3 Stone Path Survey Sheets

Section 3, the Stone Path		Hand Build		Survey Sheet No. 21 + 22
ing Route		Work Required	Description	
	18m		<p>82m Stone Pitching</p> <p>Install 3 no Water Bars</p> <p>Install 82m Revetment</p>	<p>500mm-1050mm</p>
	5m		<p>52m Stone Pitching</p> <p>Install 3 no Water Bars</p> <p>Install 52m Revetment</p>	<p>500mm-1050mm</p>
<p>Sand Large Cam 582006 171820446</p>	5m	<p>Work Required</p>	<p>Description</p>	<p>Existing Path & Features</p>

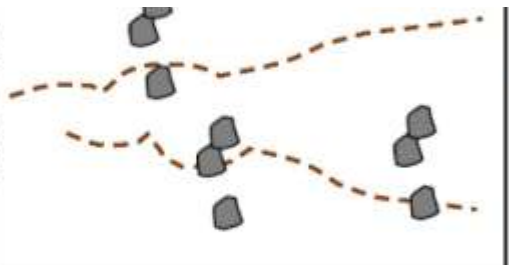
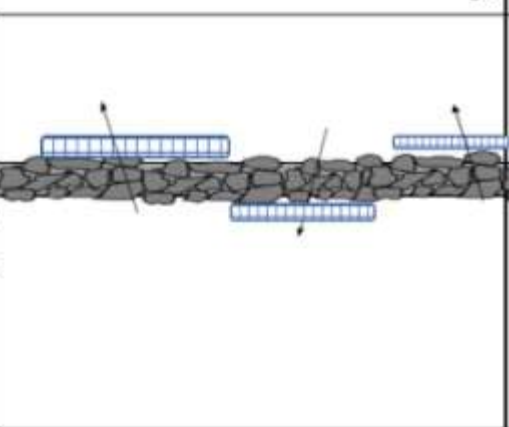
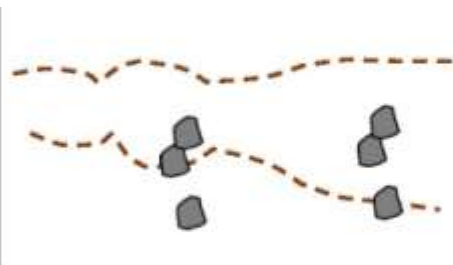
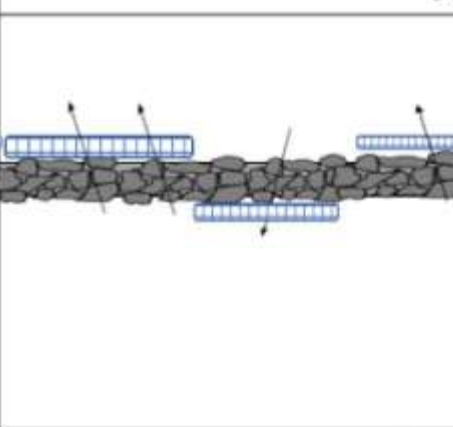
Existing Path & Features	G(°)	P.W. (m)	Work Required	Description
	21°	900mm- 1050mm		<p>63m Stone Pitching Install 3 no Water Bars Install 63m Revetment</p>
	18°	1050mm		<p>96m Stone Pitching Install 4 no Water Bars Install 96m Revetment</p>

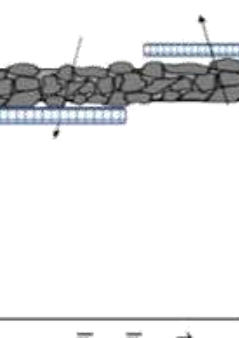
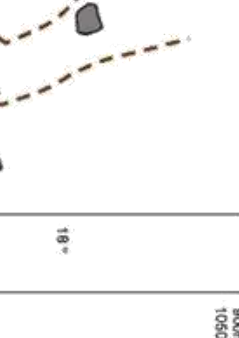
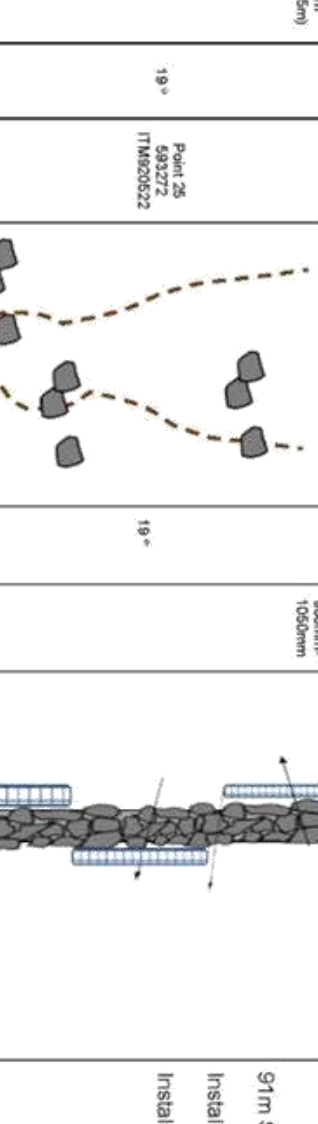
Path Name: Erigal – Section 3, the Stone Path		End 593191 ITM920553		Survey Sheet No. 25 + 26	
Existing Route			Work Required		
149m (2404m)	18°	Point 26 593191 ITM920553	900mm- 1050mm		149m Stone Pitching Install 4, no Water Bars Install 149m Revetment
91m (2256m)	19°	Point 25 593272 ITM920522	900mm- 1050mm		91m Stone Pitching Install 4, no Water Bars Install 91m Revetment
Dist	Qm	Boundaries	Qm	P.W.	Description
Elevation Path & Features					
					

9. Section 4: Summit Approach (2404m to 2824m Chainage)

Section 4 is the approach to the summit on more robust ground. Once the path begins to level off, and as the top part of the mountain is approached the surface becomes much stonier, harder and with bands of bedrock and outcrop protruding. The main issue here is path spread, and particular multiple parallel routes running very closely to each other along the ridge line. The key objective for work here is to reduce the number of paths, and concentrate use on a single line to the higher part of the ridge, and away from the more sensitive habitat on the North slope



Multiple lines on the broad ridge, with path spread creeping down the North Slope into the more sensitive habitat

A method statement for light touch works is included within the appendices (**page 68 Specification 8**). For Section 4 work will be focussed on alignment onto a single route, landscaping and blocking on the parallel paths, and preparing the ground for natural regeneration. This work does not involve construction but is restricted to landscaping and light touch works designed to confine walkers to a narrower robust line of access.

10. Materials

The crux of this project is in many ways effective logistics in relation to sourced materials. For the route to work on this protected landscape, it will have to appear as natural as possible. For it to appear as natural as possible the materials used will need to match those to be found on site. This will require quartz based aggregate for the peat path, and weathered hill won quartz block stone for construction of stone pitching, drainage features and revetment.

Quartzite aggregate will go down with a fairly light orange colour, and the silicon heavy material has good binding that will quickly weather out via rainfall to the same colour as any exposed hill materials. The silt will have a neutral effect on the chemistry of the bog and water runoffs, being of the same ph value of the material that is on the site.

A quarry has been found in very close proximity to the site. The Gillespie's quarry near Gweedore, and in close proximity to the windfarm looks to provide identical material to that on the site at Errigal. The site is located at 584293 ITM 923629



Operational Quarry near Gweedore

Construction rock for building the stone pitching, stone built features and the revetment would be best won from the hill itself. A range of sites have been identified across the hill where boulder scree has been found with the range of stone sizes to suit.



The trick to making work such as stone pitching and water bars appear ‘natural’ is to use stone that fits into the landscape, that is of the same type as the mountain is made out of, that is fitted together in irregular shapes, with irregular lines, and most crucially that is weathered to give an impression of age and nature coming together in a unique landscape.

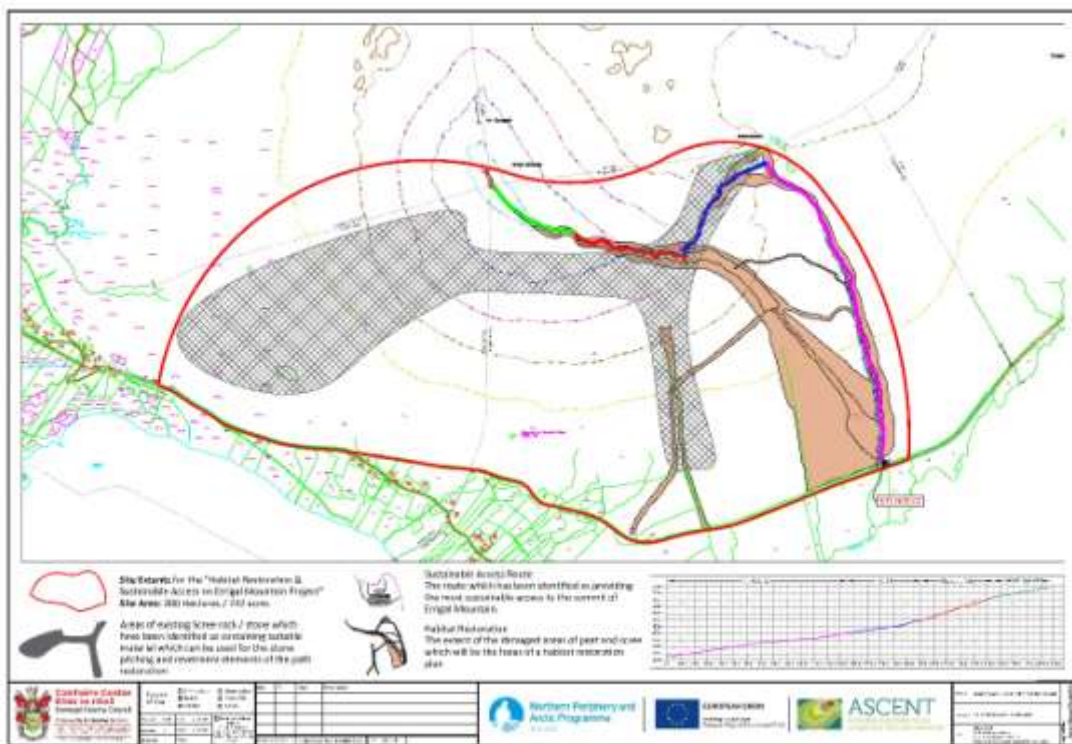

Map showing proposed areas to take stones from on the hill. Stones should be taken over a wide area with not too many from any single location.

11. Method Statement

Overview

The techniques and design for works has been selected with the natural heritage and landscape qualities very much in mind.

The techniques design and method have been put together with the principles of prevention in mind in order to:

- Avoid risks
- Evaluate the risks that can't be avoided
- Combat risks at the source
- Adapt the work to the individual
- Adapt to technical progress
- Replace the dangerous with the non-dangerous or the less dangerous
- Develop a coherent overall prevention policy
- Give collective protective measures priority over individual protective measures
- Give appropriate instructions to workers

Method Statement

There are 4 sections of work, all with some overlapping techniques and requirements that must be allowed for in the contractor's risk assessment.

All of the work will require skilled and experienced workers who know how to use the techniques well, have good experience of mountain path building in remote locations, and are skilled and are well trained in the health and safety requirements of the site.

All of the work will require workers to have suitable clothing and PPE to work in difficult conditions, including warm under layers, waterproof top layers, and protective footwear.

All of the work will require manual handling, use of hand tools and will expose workers to risks from environment, and all of this must be dealt with through effective training for the work force.

The team must have a comprehensive First Aid Kit, a qualified First Aider, and all workers must know procedures if there is an emergency.

Sections 1 and 4 will require helicopter use, and it is vital that only those trained and certificated to work under heli's and load and unload, should be involved in the hooking on and off the hoppers. The helicopter will likely provide their ground staff for this.

Site welfare will require some thought from the contractor, particularly on the upper mountain. Use of kit, antiseptic wipes etc can be considered. It may be possible and practicable to have a welfare unit for Section 1 but this will not be practicable for sections 2, 3 and 4.

Site 1 The Peat Path – Step Sequence of Operations

The site will require a floated path for the vast majority of the way, and this will need to be on geotextile base

- The tray must be excavated to 100mm and available sods placed to the side
- The ditch should be excavated, and available sods placed to the side
- Terram T1000 or equivalent should be rolled along the path tray to the required width (1200mm up to the 720m mark and 1000mm beyond this), plus 150mm either side. This will float the path.
- Tensar Geogrid should be rolled over the Terram layer. This will prevent movement of material in the sub-base and lend added strength to the aggregate fraction laid on top.
- The sods that have been set to the side should be used to form a path edge
- The rocks for construction of Water Bars, Cross Drains and Anchor Bars should be bagged on the hill from identified sites in long handled heli bags, to no more than 1T per bag. On the airlift the heli-bags should be transported by helicopter to close to the sites where the stone will be used to build the features
- The bags should be emptied, holes excavated and the features constructed (see appended designs and construction methods)
- The Aggregate should be brought to site from the quarry and stock piled in the car park, and this will need to be closed for public use during this phase of the work.
- A small excavator will be used to load the hoppers, and the hoppers will be provided by the heli company.

- The team will be dispersed across the path in groups of two to lay the path once the hoppers are emptied, in such a way as to leapfrog each other as the helicopter operation takes place
- The hoppers will be loaded from the excavator with 3 hoppers in use to ensure that one of them is in the air at all times.
- The helicopter will fly the loads to the workers, who will spread the contents, and this operation will repeat until all of the aggregate is laid. This operation is likely to take up to 5 days, and the public should be prevented from entering the site at all times during this operation. The existing line should be used for public access.
- Once the aggregate has been laid the site will be made good with landscaping to promote natural regeneration of the surrounding eroded hill ground.
- Turves with a 4m corridor can be utilised to create sod islands to landscape the exposed peat, and provide islands of seedstock that will in time through natural processes generate growth on the bare ground
- Once all work has completed the tools, heli bags and any other non-natural materials should be removed. The car park must be cleaned and tidied and otherwise made good to Donegal County Council's satisfaction prior to sign off of the project work.

Site 2 The Rib – Step Sequence of Operations

This is light touch work on the hard and robust ground as it ascends to the ridge.

- A single line will be defined by removal of stones and sod where necessary
- These materials will be used to reinforce the edges of the single line to encourage people to stay on the path line. Blocking and landscaping will be utilised at key points where walkers may be tempted to deviate from the intended path line. Use of sods and stones to roughen the path edges and provide psychological barriers to prevent people migrating downslope will be utilised at key points and at places where walkers may be tempted to deviate from the intended line
- The site will be made good, and it will necessary to ensure that only weathered stone is visible and that all sods are planted such that root matter is not exposed.

Section 3 The Stone Path – Step Sequence of Operations

- The stone materials will be bagged in long handled heli bags to no more than 1T from identified locations
- Only quartzite stone will be used, and this should be weathered as much as possible
- The bags will be flown and secured onsite adjacent to the where the path will be built.
- Walkers will not be able to access the site whilst the helicopter is flying overhead, and this will need to be managed by the contractor on site. However information in the car park and social media would be very helpful in handling public expectation. This operation is likely to last for several days.
- The public can pass through the site at other times, but the contractor must make sure they are guided through active parts of the worksite safely by their staff.
- The bags of stone will be emptied, the tray excavated and the path will be stone pitched using the quartzite. Detailed specification and construction are appended.
- The Revetment will be constructed on the edge of the path line.
- The water bars will be integrated into the pitching construction as the path is built
- The ground on either side will be prepared to encourage natural regeneration with materials left there. Where there is any sod available it must be used carefully used and to maximum effect, and weathered scree can be used to help protect the path edges and discourage walkers from deviating from it.
- Once works are complete all tools, equipment, materials and heli bags should be removed from and the site made good to Donegal County Council's satisfaction.

Section 4 – Summit Approach Step Sequence of Operations

This section will require definition of a single line and blocking off of the other ones developing.

- The line on the upper side should be made obvious, and continuous through removal of stone or sod where necessary.
- The lower path lines should be blocked at key points where walkers may feel encouraged to creep downslope onto lower lines. This should be done only using weathered stone and sod locally won.
- The lines that are to be closed down should be broken where possible by use of weathered stone and sod where available, to tone down their linear nature.

- Where possible natural features should be replicated to use for blocking e.g. groups of stones placed in a way that would look natural or by placing weathered stone in a way that it integrates with protruding bedrock
- At the end of the works all tools equipment and materials should be removed and the site made good to Donegal County Councils satisfaction

Appendix A Specifications

Path Construction Design Specifications

Specification 1 – Raised Aggregate Path Construction

49

Aggregate material down
to be required for 1.2m

1200

1 - 'As - dug' new Path Construction (1200mm clear path width to the 720m Mark on Section 1, up to 1000mm beyond this; to be used on sections with 1:1 slope)

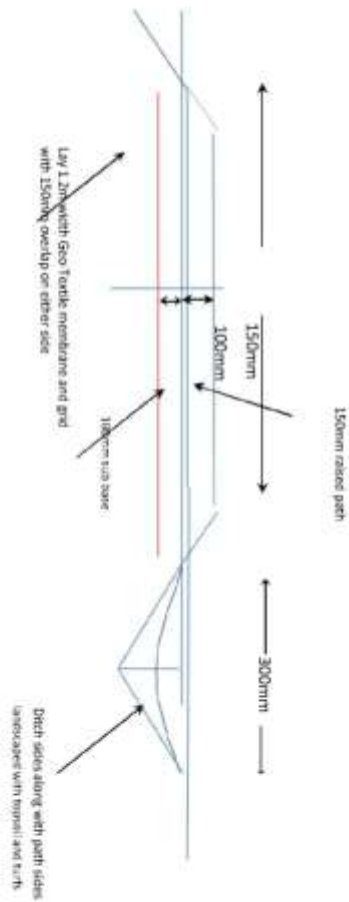

Function

The aggregate path provides a hard wearing, durable surface to withstand the expected pressure of use. It should be comfortable to use so that walkers will keep to it and not walk on surrounding vegetation or take alternative routes. Path edge definition with sods and boulders, and site restoration, will help to control this. The path should be free draining, with drainage features incorporated, to withstand the expected weather and waterflow.

Use locally won aggregate to re-construct existing path to a width varying between 850 - 1050mm, and a minimum depth of 250mm. Grade base material depth to allow 50mm of graded surface material, with a binding of fine material. Compact to form draining cambers or cross-falls. Use excavated material with turves and boulders to define and contain the path edge.

DIMENSION GUIDELINES

- the width should be naturally varied along the length of construction; the average width will be determined by the path assessment - this may be as little as 850mm, or up to 1200mm;
-

- the average tray depth should be no less than 250mm; the path tray base should be a solid, natural mineral soil foundation; where path tray excavation reaches 300mm and the ground is still soft, or wet, geotextile will be required the depth of construction, or path tray, will depend on the nature of the ground and depth of erosion; softer ground, and heavier use will require a deeper tray and a sub base;
- the depth of surface, base and sub-base will depend on the tray depth, and material available; minimum depths should be:
 - 50mm of compacted surface material.
 - 100mm of compacted base material.
 - 150mm of sub-base material.
- the surface layer should always be at least 50mm to prevent exposure of the rougher base course through pressure of use; combined base and sub-base depths can be varied, depending on material source and stone size available (see below);
- the surface camber or crossfall should be between 2° to 5°, to effectively shed surface water;
- the finished path surface should be no lower than the ground at the path edge to avoid water collecting here.

MATERIALS

On-site aggregate will be won from the surrounding area from borrow pits. Material should not be used 'as dug' but graded for each path layer. Where feasible this may be done using purpose built screens with different size wire mesh.

The source available may dictate the grading but, as a rough guide, the largest size stone for each layer should be at least 50% of the layer depth. For minimum depths:

- sub-base stone would be between 75 - 150mm, graded down to approximately 10mm.
- base stone would be between 50 - 100mm, graded down to 5mm, with some fine particles.
- surface stone would be 25 - 50mm, graded down to fine particles.
- binding stone should always be no more than 5mm graded down to very fine particles.

Stone should be angular for good interlocking. Binding material should have a high mineral content and be free draining, i.e. with not too much peat or soil. In some places the binding layer may be clay.

Specification 2 – Stone Waterbar

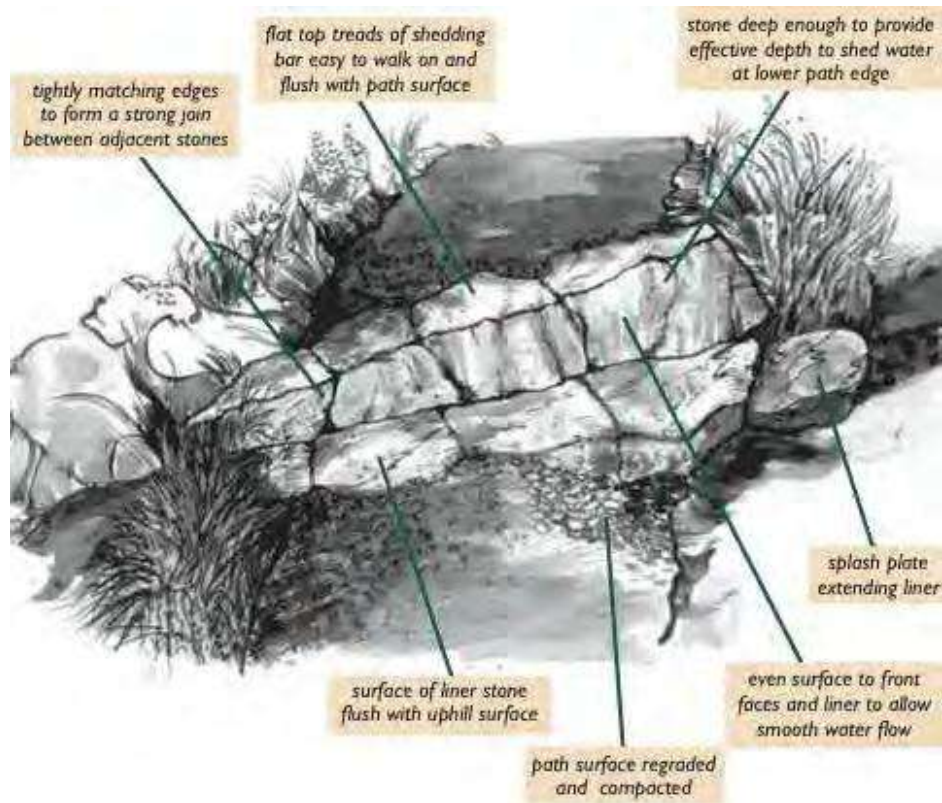

Function

The key function of a waterbar is to divert running surface water off a sloping path. Without them the path surface scours and gradually becomes so rough, gullied and wet that walkers will not use it. Waterbars can also help to stabilise the path surface, by providing a solid anchor. A waterbar does a different job from crossdrains, which are generally used to take water from uphill ground, across the path.

Use local, weathered stone (quartzite) to construct a waterbar, between 30°- 45° to the path line. Bar depth should be a minimum 100mm rising to approximately 150mm. Liner should provide a draining fall of 5° minimum. Extend by 300mm on each path side. Include splash plate if ground drops steeply. Re-construct the path at least 2 metres above and below the waterbar.

DIMENSION GUIDLINES

- the angle of the waterbar across the path should provide an adequate fall and be between 30°- 45° to the path;
- the draining fall in the liner across the path should be no less than 5°, and up to 15°;
- the bar upstand above the liner should effectively catch and disperse the water and be a minimum of 100mm depth at the upper path edge rising to approximately 150mm at the lower edge, but not present a barrier to path user top surface of the bar stone should be flush with the downhill surface;
- the surface of the liner stones should be flush with the uphill surface and slightly angled down to the bar stone;
- the bar should extend approximately 300mm either side of the path, as the site allows, to prevent water flowing back onto the path, and walkers from walking around and damaging the path edges.

MATERIALS

Local stone selected should be in its natural form, preferably weathered. The amount of stone needed will depend on the path width. The following points should be noted when selecting stone.

- block stone for the bar should be large enough to withstand the pressure of path use, the greatest waterflow, and frost heave - if it can be moved and lifted easily it will be too small;
- bar stones should be deep enough for half the depth to be below the liner level, and to provide the required upstand depth;
- the front face of the bar stone should have no protrusions and provide an even surface with adjacent bar stones;
- the top face, or tread, of bar stone should be large enough and suitable for walkers to step onto;
- liner stones can be smaller, but must be at least 200mm deep to prevent under-mining and movement by heavy water flow;
- the upper surface of liner stones should have no protrusions and provide an even surface with adjoining liners.

Specification 3 – Stone Cross Drain

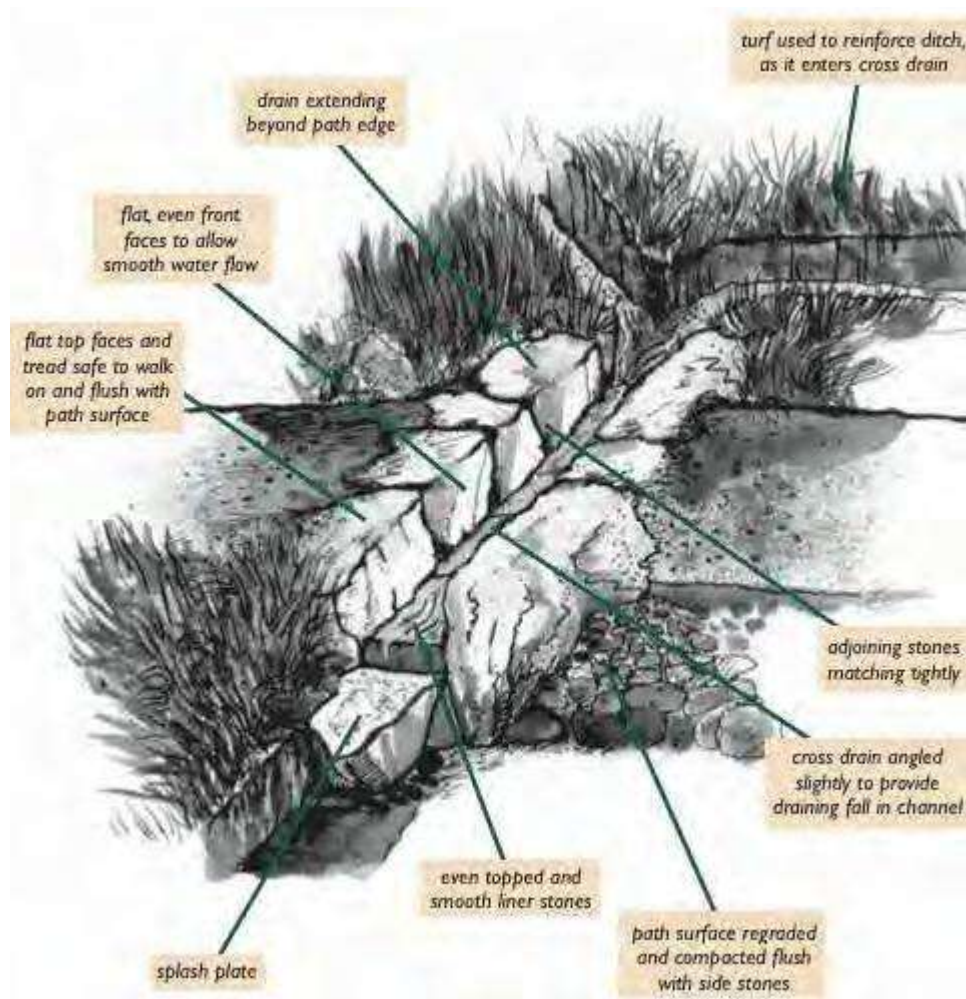

The stone cross-drain is a traditional, and versatile, drainage feature, sometimes referred to as an open culvert, or a stone lined ditch. The elements of the design used today remain relatively unchanged from those used on stalkers paths and hill tracks.

FUNCTION

The main purpose of the cross-drain is to channel water from above the path to the lower side. The source of the water may be from small streams, springs, mossy flushes, areas of uphill surface water or seepage. Cross-drains are also used to collect and disperse path surface water at low points on the path, or on sloping paths where water bars are not suitable for the path use

Use local weathered stone to construct a stone cross-drain with a

minimum channel depth and width of 300mm. Extend by 300mm on each path side. Stone line the full length of the drain base, with a gradient of 5° minimum. Allow for an outflow splash plate and approximately 10 metres of in and out flow side ditch. Construct path at least 2 metres either side of the drain

CONSTRUCTION

The cross-drain has two main components - side walls and a lined channel base. They provide a solid channel across the path which is easy to clear of silt and debris, and is relatively self-cleansing.

- side walls provide the channel width and depth, and are comprised of two lines of block stone across the path, placed with faces to channel the water flow - essential 'stone extensions' of drainage ditch or water course sides;
- lined channel base is comprised of a row of liner stones, between the side walls, which helps to stabilise the side stones and prevents undermining by water.

A splash plate stone extending the liner stones at the outflow may be required to prevent erosion, especially where there is a steep drop, or soft ground is present.

Inflow ditches collect the water flow to be taken across the path from the water source. The ditch for the outflow may connect with the drainage system, or lower water courses, and will ensure that water is dispersed away from the path edge.

DIMENSION GUIDELINES

These will vary according to the nature, source and volume of water to be channelled, and the direction and dispersal of waterflow.

- the cross-drain is normally at a shallow angle across the path, depending on the nature and direction of flow; the angle may need to be increased in order to provide an adequate fall in the channel;
- the draining fall in the channel should be no less than 5°, and up to 10°, to ensure a clear run;
- the channel width and depth can be variable, but will normally be a minimum of 300mm deep and 300mm wide; this will allow room for a spade during maintenance, and less chance of being choked with larger debris;
- the channel should not be so wide as to provide an obstacle to path users;
- the top surface of the side stones should be flush with the path surface, to allow

collection of path surface water, and to provide a tread surface for walkers stepping across the channel;

- The Cross-drain should extend approximately 300mm either side of the path, as the site allows, to protect path edges and prevent water flowing onto the path.

MATERIALS

Large block stone is required, preferably available, from within reach of the path. It should be large enough to withstand the pressure of path use, the greatest waterflow, and frost heave. If it can be moved and lifted easily by one person it is probably too small.

It should be used in its natural form, preferably weathered (see Section 2.0), although it may be necessary to shape the stone slightly by chipping off minor protrusions. The quantity of stone required will depend on the size of cross-drain to be built and the path width.

Points to note when selecting stone.

- side, or face stones should be deep enough for at least 1/3 to be below the surface of the liner, and to provide the required channel depth above the liner;
- faces forming the channel side should be as even as possible, with no protrusions that may hamper water flow or collect debris;
- tread faces should be as even as possible, with no protrusions for walkers to trip on;
- the shape should match evenly and tightly with the adjacent side stones;
- liner stones can be smaller, but must be wide enough for the required channel width, and at least 1/3 of the depth of the side stones; also large enough to prevent undermining by fast and high volumes of water;
- upper surfaces should provide an even channel surface with adjoining liners and have no protrusions to hamper water flow and collect debris.

Specification 4 - Anchor Bars: Aggregate Paths on Slopes

Where an aggregate path is constructed on a slope greater than 8° (15%), there is the risk of the material migrating down the slope, particularly if the binding properties are not good, or there is a high level of path use. To help prevent this occurring stone anchor bars can be incorporated into the path structure. However, not all paths on gradients require anchor bars. They may not be necessary if the surface and base material binds well, or if the path is well protected by drainage features, and the level of use is low.

A range of options should be considered for paths on gradients including ensuring that there are plenty of waterbars and using short sections of pitching. The selection of techniques needs to be based on a judgement of how the path will be used and maintained bearing in mind that long flights of pitching at relatively low gradients do not get used and that aggregate is not stable on steeper slopes. There is also a need to consider the potential for mountain bikes bouncing on the aggregate off the anchor step and actually speeding up deterioration.

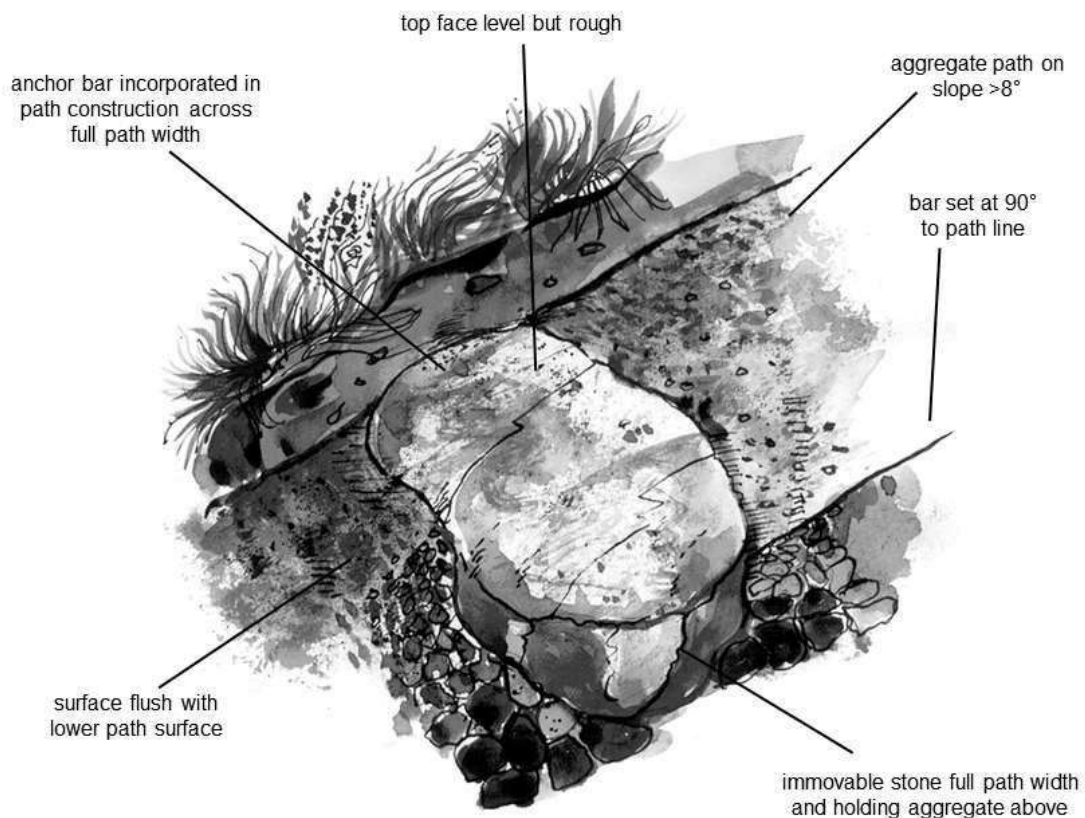

Function

Anchor bars form solid, immovable structures within the path construction and, depending on their spacing, hold the aggregate on the slope above. The anchor bar may be used with water bar construction, as the stabilising stone below the shedding bar stones. Anchor bars can be added to existing paths that are showing signs of movement.

Bill of Quantities (example)

Re-construct existing path with aggregate to a variable width, between 600-1000mm. Use large block stone to construct anchor bars every 10m, across the full path width, and flush with the path surface on the upper edge.

Positioning of Anchor Bars

Anchor bars will generally be used on paths with a gradient between 8° to 16° (15-30%), but if the surface material does not bind well anchor bars can be useful on slopes as low as 5° (10%). On mobile slopes extra effort should be made to improve the binding Properties of surfacing and to compact firmly, as well as carefully, considering the spacing of anchor bars. Depending on the gradient and surface material anchor bars should be positioned at intervals of between 3 and 20 metres.

The following table gives a general guide to spacing.

Gradient of Path			
Gradient	low 8-10°	medium 10-12°	high 12-16°
Spacing	10-15m	5-10m	3-5m

Construction

Components

The anchor bar is an informal structure, comprising one or two large block stones, set across the path line. The block stone is sunk into the path with the top face just visible as a part of the path surface and should not normally stick up like a step. Depending on the gradient and the size of stone available it may be necessary to have a double row, or two courses, of stone.

Dimension Guidelines

- the bar should span the full width of the path line; this may require the use of more than one stone;
- the bar should be positioned at approximately 90° to the path line;
- stone should be set in approximately 200mm deeper than the path construction depth, so that the bar is an immovable, "independent" structure, which will withstand the weight of aggregate and the pressure of use;
- the top surface, or tread, of the stone should be flush with the path surface; the lower edge should not normally form a step up from the surface below;
- on steeper paths it may be necessary to have a slight step, to avoid the tread being at an uncomfortable angle to walk on;
- a double course of stone may be used to provide the height gain required without creating too high and unnatural a step.

Materials

The local stone selected should be in its natural form, preferably weathered. The

the stone should be large enough to hold the compacted aggregate above and the pressure of path use - if it can be moved and lifted easily it will be too small;

- the stone should be at least the width of the constructed path, if two stones are used each should be at least half the path width; it is better for stone to extend outside the path edges than be too narrow;
- the stone should be deep enough to bury into the ground by approximately 200mm below the path base;
- it should have a level, but rough top face for the tread; it should have no large protrusions, but not be so smooth that people will slip with gravel on the surface.

Method of Construction

Anchor bars are built into the excavated path tray before the aggregate is laid.

Step 1

Excavate a trench

- dig a trench approximately 200mm deep across the full width of the path tray;
- the trench should be wide enough to allow for the width of the bar stone and the depth required for bar stone tread to be flush with the path surface.

Step 2

Position the anchor bar stone or stones

- set the anchor bar stone so that the surface will be flush with the compacted path surface, and not create a step, unless the path is steep;
- if a second stone is necessary they should be tightly butted together to form a solid bar across the path and provide an even tread surface;
- wedge and pack any gaps with smaller stone, and backfill the trench firmly, to form an immovable structure.

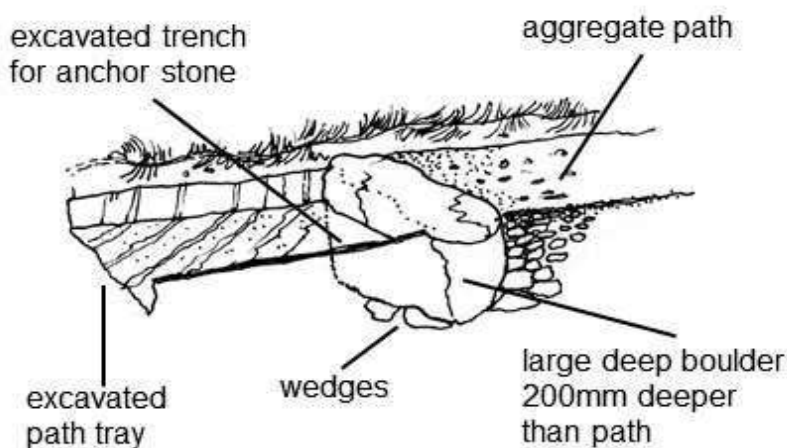

Step 3

Construct the aggregate path.

- take care not to dislodge the anchor bar when compacting the path material above and below the bar;
- make sure that the surface layer is compacted to be flush with the top and bottom edges of the bar stone or stones.

Troubleshooting

Key points to watch out for:

- Use large stone, if possible one to span the full path width - too small a stone will become loose with the weight and pressure of the path;
- • keep the bar flush with the uphill path surface - avoid steps up from the downhill surface;
- • avoid using anchor bars on too steep and mobile a gradient – short sections of pitching and aggregate may be a better solution.

Variations

If large block stone is not available the anchor bar may be formed by constructing short sections of pitching. This will also be suitable on steeper gradients where double rows of large block stone, or longer sections of pitching, may be required to "take up" the gradient without creating high and formal steps.

An anchor bar can be built 2 or 3m down a path from a water feature, such as a waterbar. The anchor bar will hold the surfacing on the ramp below the waterbar, creating a more durable walking surface and preventing erosion behind the face stones.

A further variation on steeper slopes is to build anchor bars with a step. This reduces the gradient of the aggregate between the anchor bars, but will require more maintenance and is likely to be less successful on very mobile slopes.

Maintenance Tasks

Anchor bars require maintenance on a regular basis:

- check the stability of the stonework - re-pack where there is movement or any visible gaps;
- re-pack aggregate surfacing above and below the bar where compaction or erosion may have taken place;
- if anchor bars are not preventing downhill movement of aggregate, some re-alignment of the path may be required using short sections of pitching and aggregate.

Often anchor bars are added to an existing aggregate path on a slope, at time of maintenance, to solve problems of surface movement.

ENVIRONMENTAL SENSITIVITIES

Use natural looking weathered stone, that will blend in with the surrounding landscape sod over the edges of the anchor bar where they extend outside the path edge.

HEALTH AND SAFETY HAZARDS

Use safe lifting techniques when moving or positioning stone for the anchor bar.

TAKE CARE

The path's dynamics must be carefully considered before deciding to use anchor bars, in particular consider the gradient of the path, the mobility of path material, and the levels of use particularly on well used steeper paths where the surfacing does not bind well, migration material is likely to create 'steps' below anchor bars as the surfacing migrates downhill.

This encourages people to leave the path to avoid the step, creating braids and can increase the chances of erosion by bikes dropping off the step help avoid braiding by ensuring that anchor bars extend past the edges of the path or use blockers/vegetation mounds.

Specification 5 - Bank and Slope Stabilisation

Upland slopes are prone to slippage, particularly when vegetation has been lost. Initial loss and erosion may be caused by pressure of use, but fragile vegetation, thin friable and mobile soils, high rainfall, and frequent freeze thaw action all contribute. Slopes will need stabilising if a path solution is to be effective.

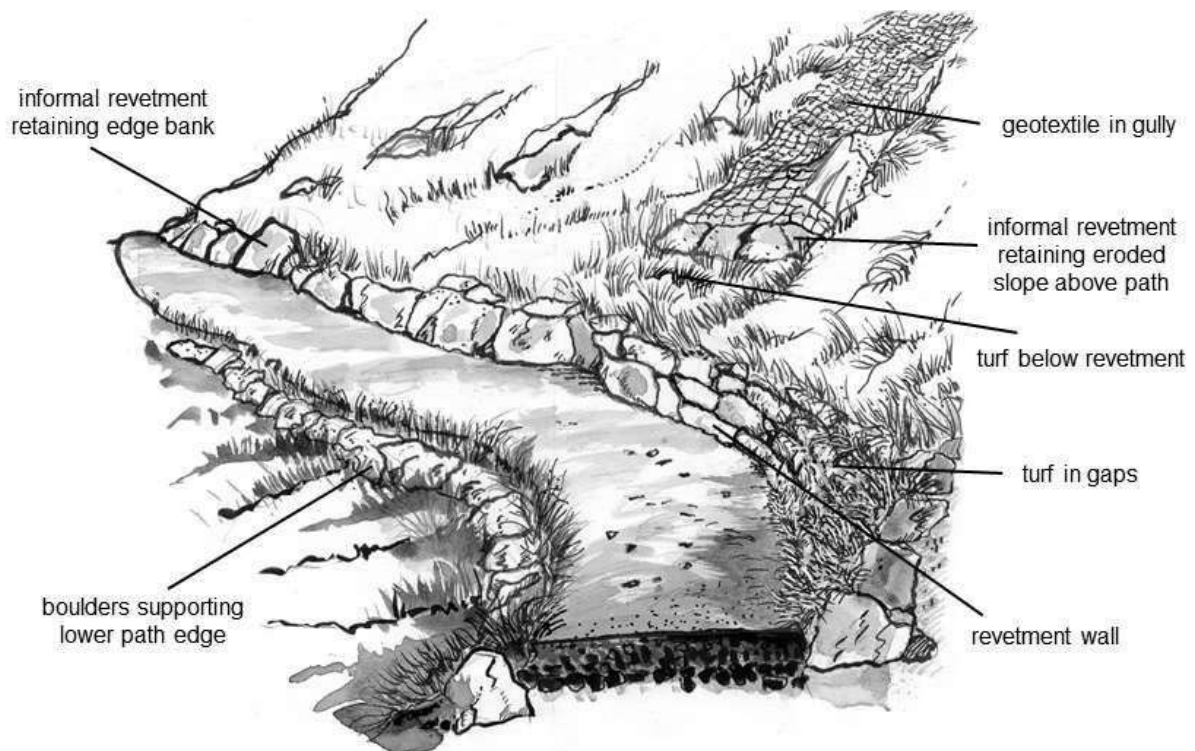

Function

The revetment wall is solidly built to retain loose or unstable ground on steep slopes. The stabilised slope will then provide a better base for revegetation. Revetments are also used to support and consolidate banks along path edges. The most typical situations for its use are:

- on open eroded slopes, or gullies associated with the old path alignment;
- where the path traverses a slope, either on one line or zigzagging;
- to support a lower path edge from collapsing down the slope;
- to retain the bank or slope above from collapsing onto the path, either at the path edge or on the slope above.

Bill of Quantities (example)

Using natural weathered stone construct an informal revetment wall to retain the slope above the path. The construction must be solid and stable, with large foundation stones, off-set joins, pinned and backfilled firmly. Pack gaps between the courses with sod, and sod over the top to blend with the upper slope.

Where revegetation over an eroded slope is necessary the revetment may be combined with sod banks and transplants, or geotextile with seed (see Restoring Vegetation).

Construction

The revetment is a rough-faced, random coursed, drystone wall. On steep slopes the structure may need to be a formal retaining wall, of approximately 500mm height, or more. Preferably, a less formal approach should be used, with large boulders butted together along the path edge to support the banking. Both should be made to look as natural as possible by incorporating sods into and over the structure.

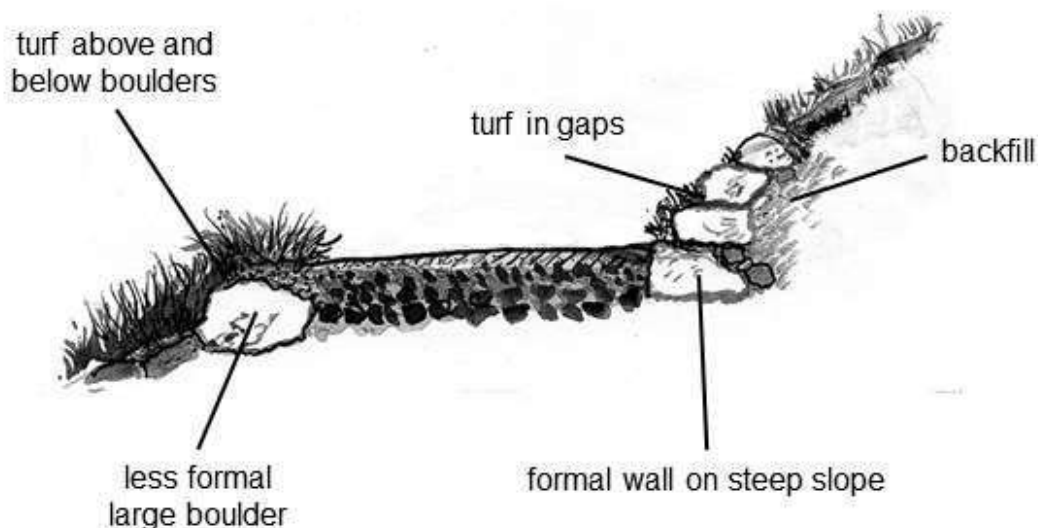

Materials

Revetments are built from the following:

- large boulders for informal revetments;
- variable sized, block stone for formal revetment walls; spoil for back-filling;
- sod for landscaping the revetment.

These are described in detail in Materials and Use. Stone for revetments should be in its natural form with the outer faces weathered, preferably lichen or moss covered, to blend with the surroundings

Method of construction

Foundation

The key to a solid revetment is the foundation. Whether it is the more formally constructed wall or the random boulder edge, a solid base should be excavated and levelled to build on. This should be to at least one third of the depth of the base stone.

Courses

- use the largest stones for the wall base stones, progressing with courses reducing in size towards the top; the final course should use stone that is large enough to form a solid top to the wall;
- the courses should form a batter, leaning into the slope, to provide more resistance to any slumping of the slope behind;
- outer stone faces should not protrude, as these may be used as steps, by people or animals, to climb over the wall, which will ultimately result in weakening of the structure.

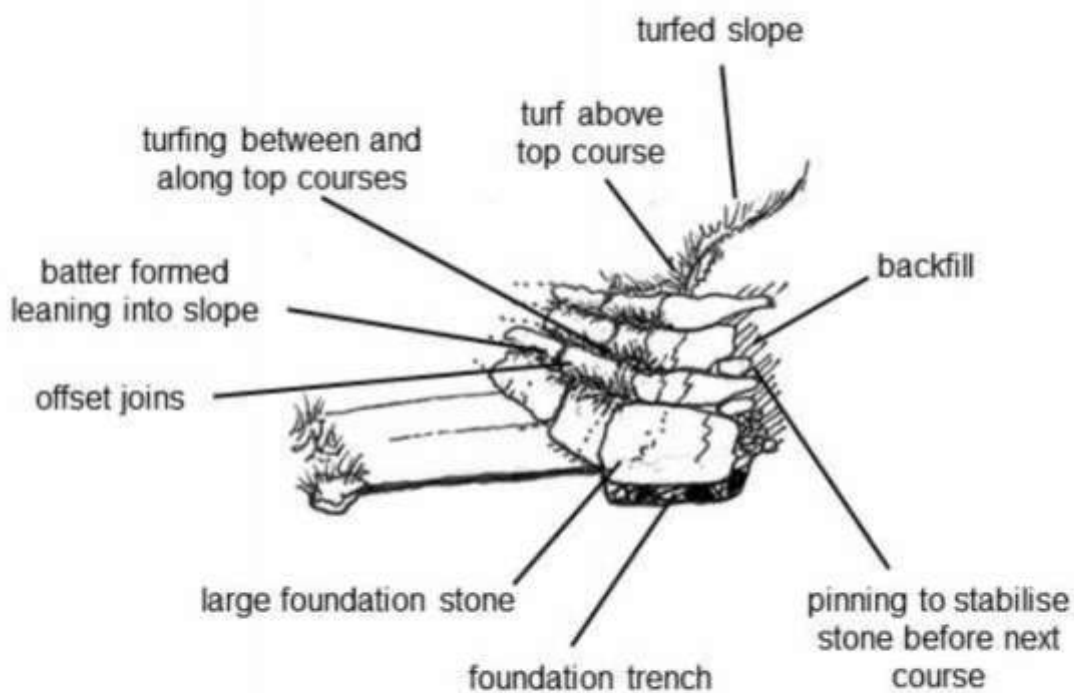

- lay the stone a course at a time, butting adjoining stones tightly, and with offset joints, to provide a solid structure;
- pin each course from behind with smaller stone wedges, to ensure that no movement occurs, before the next stone is laid;
- backfill any space behind the revetment as each course is laid; it is essential that this is packed tightly to minimise movement and settling of the soil which inevitably happens after construction is complete.

Finishing

- fill gaps between courses on the face of the wall with sod off-cuts to help create a natural appearance;
- revetment above the path should be topped off with sod, and landscaped into the upper slope;
- to keep walkers off the top of revetments below the path edge, spoil and sod should also be used on the path edge;

- revetments supporting the lower path edge should have spoil and sod in front of the foundation stones, to help stabilise and blend them with the lower
- slope; revetments on open slopes should have sod and spoil above and below to blend into the slope and aid stabilization.

Troubleshooting

Key points to watch:

- always build on top of securely wedged stone - if the course below is loose then all those above will be unstable
- extend the revetment by one metre past the end of the bank that requires stabilising, to prevent banks collapsing around the ends

Maintenance Tasks

The following maintenance task should be carried out regularly:

- re-packing of loose stone work with sod or stone wedges; re-
- placing sod of any areas where sod has died or been damaged.

Specification 6 - Stone Pitching

Introduction

Stone pitching evolved from the smooth cobbled surface of ancient tracks and roads, into the traditional rougher cobbling of stalkers paths, suitable in the upland environment. Further adaptation developed the technique for recreational use, and to merge with the landscape.

It has gone through many years of experimentation, such as using larger boulders placed with a horizontal surface rather than angled down the slope, and this is ongoing. Stone pitching should only be used where there is no viable alternative because it is uncomfortable to walk on, particularly in descent. On steep slopes efforts should be made to align the path so that only small sections of pitching are required interspersed with an aggregate path.

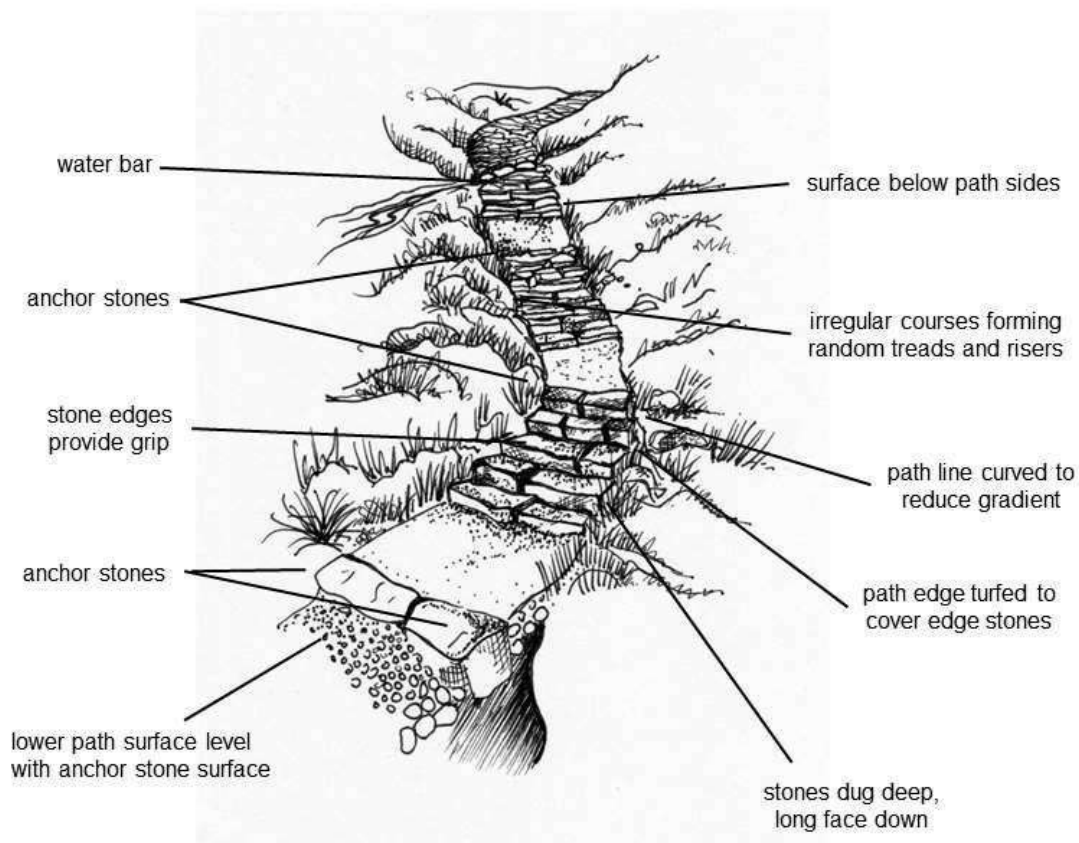

Stone pitching provides a hard-wearing surface for steeper paths. It is used where aggregate is impractical or has failed due to the gradient and erosive pressure of feet and water. The pitched surface can withstand these pressures, and, with sensitive construction can blend aesthetically with the surrounding landscape.

The best sites for pitched paths are where they merge naturally with the rocky appearance of the landscape and provide an easier route than the surrounding ground. To enhance the aesthetic appearance they should avoid steep straight lines, and incorporate curves and variations in width, making use of natural features wherever possible.

A pitched path is not always easy to use. It does not absorb impact, and may be steep and rough. If the surrounding ground is easier, or more comfortable to walk or ride on users will cause further erosion by short-cutting or walking on landscaped edges. An alternative of short vegetation will invariably be used if it is available.

A comfortable walking surface is therefore essential for both ascent and descent, in all conditions, which means that treads need to be at a low angle to avoid becoming slippery when wet or icy. It is also very important to ensure that site restoration and landscaping encourages people to stay on the path. To encourage success of the work path lines should minimise the amount of pitching required. This may require altering the path line and managing zigzags to reduce the gradient.

Pitching may act as a hazard to bikes or be treated as a 'thrill feature' if poorly executed or badly placed – low gradient pitching should therefore be avoided.

Bill of Quantities (example)

Use local, weathered stone to construct a pitched path, average 1.2m wide. Irregular, random treads must be comfortable to use, with risers of no more than 150mm. The construction must be solid with stones fitting tightly, well packed, with overlapping joints. Use excavated sods, spoil and boulders to define and contain the path edge.

Construction

After choosing an alignment that fits the landscape and requires the minimum amount of pitching, the main considerations are:

- provide a good surface for users, particularly on descent; allowing walkers to place a whole foot on a single tread wherever possible;
- reduce the gradient with angled lines across the slope and intersperse with aggregate path wherever possible;
- produce a structure that is solid and immovable, and will withstand the most extreme pressures of use and water flow;
- incorporate drainage features for a path surface that will not be under-mined, will be long-lasting and require the minimum amount of maintenance;
- avoid having an excessively large drop-off which can cause bikes to 'ground' the chain ring on the descent;
- ensure that the bottom step is flush with the path as this stone will become higher than the aggregate below due to the compaction and migration of the aggregate; pitching changes the rhythm of walkers' strides and a few lower steps to lead into it helps to encourage use, rather than an abrupt big first step;
- landscape carefully to further encourage walkers to stay on the path.

Components

Stone pitching comprises various stone shapes and sizes, used in rough courses across the slope, to provide a series of irregular and random low steps and footholds, with a cobbled

or bouldery appearance.

The largest block stones are used as anchor stones at the bottom of pitched lengths, and at regular intervals throughout the length to support the stonework above. Large stones are also used at the path edge for structural stability.

Drainage features are incorporated at regular intervals. For path surface water these will be water bars, although cross drains can also be used. It is good practice to protect the path surface below the pitching with a drain close to the bottom. The top of the pitched length should be similarly protected, but this does not need to be directly at the top of the 'flight'.

The path edges are contained, defined, and softened with sod, spoil and boulders (see Restoration Techniques).

Dimension guidelines

There are varying styles of pitching, attributed predominantly to the stone type available. The basic principles for construction remain the same.

- the overall path gradient should be kept as constant as possible by incorporating curves on short steep sections, and adjusting the pitched depth and surface level;
- the path surface should be flush with the adjacent ground, with the vegetation or sod higher than the pitching. It may be necessary to raise the path edge by placing sod and landscaping. Higher sod edges help the path to blend in fit better in the landscape as well as encouraging users to stay on the path;
- anchor stones at the start of pitched lengths should have the tread flush with the lower path surface; if a step down is created, the surface below will erode, the step will become too high, and the anchor stones will be under-mined; this will cause the pitching above to fail;
- pitching must not start anywhere other than at a change of gradient. If the path below the bottom anchor bar is too steep, then it will quickly erode away creating a step;
- path stone should be pitched with at least half the stone depth below the surface of the lower stone, and the longest side into the ground; the deeper the pitched depth the more solid the construction;
- the resulting upstand, or riser should ideally be no more than 150mm; if it exceeds 200mm it can be difficult to use.

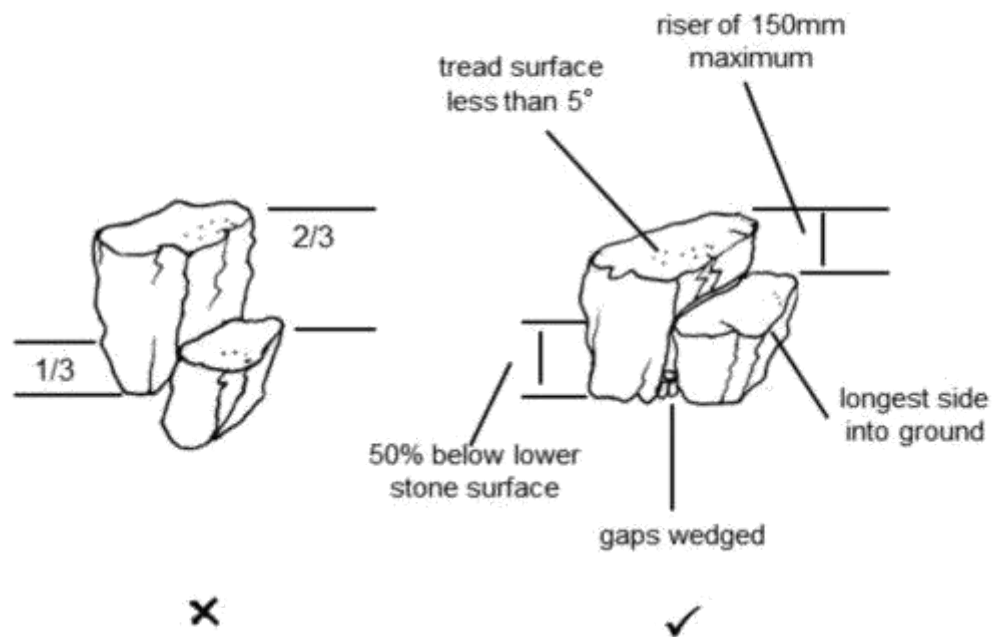

- adjoining stones should form a rough course across the path with variable upstands to avoid a formal step appearance;
- stone should be pitched vertically, with the tread surface more or less horizontal; downhill tread angles should not exceed 5°;
- it is important that the overall surface is not a sloping ramp without good footholds.

Materials

The local stone selected should be in its natural form, and preferably weathered (see Environmental Impact). The quantity of stone required for pitching is high - approximately 1 tonne for 2m, depending on the density and depth. If not enough is available in the vicinity of the path it may be necessary to import material to site by helicopter.

To avoid uniform steps a variety of irregular and random stone size should be selected. Stone varies considerably from thin slaty schists, and large rounded granite, to chunky sandstone blocks. Depending on what is available the following points should be noted:

- each stone should be deep enough to provide the pitched depth required - a general guide is no less than 300mm; anchor and edge stones will be deeper;
- tread faces should provide a "grippy" surface; not so rough that protrusions may be tripped over, nor smooth and slippery.

The best sources for stone are glacial surface deposits, scree slopes or rock falls on the surrounding open hill. Stream beds are another source but tend to provide rounded smooth stone which has to be used with skill.

Method of Construction

Step 1

Form a path tray

- excavate a path tray along the selected path alignment, to the required variable
- width; the depth of the tray should allow for the depth of the stone available, and for a finished path level below the surrounding vegetation;
- where the path line is severely eroded, to a variable width and depth, it may require realignment, infilling or narrowing, without any excavation; this can be achieved with careful use of spoil, sod and boulders.

Step 2

Set the pitched stone

Depending on the number of workers and the length of the path, pitching may be split into sections. If these are pitched simultaneously pay close attention to the overall gradient. To ensure that the path climbs at a steady rate, and avoid joining either too low or high, the next set of anchor stones should be visible to judge the height gain required.

Always start at the bottom of a section and work uphill.

- the first line of stone will be large anchor stones set flush with the lower path surface; it is essential that they are dug in deep and are immovable; they may also form the lower side wall for a cross drain at the base of the pitched length;
- progressing up the slope pitch the stone into the tray in rough courses across the slope, to achieve the required random footholds and risers;
- use large, deep stone at the path edges to form a strong edge;
- butt adjoining stones tightly together, on all side faces, maintaining good footholds;
- wedge all gaps firmly, before subsequent courses are pitched, so that all path stones are solid and immovable;
- overlap joins on adjoining courses for a sound structure;
- pack remaining gaps with smaller stone and gravel; this is essential to prevent the ingress of water under the pitching, which may cause loosening and wash out, or break up with water freeze and expansion in winter;
- incorporate waterbars or cross drains at intervals required, with the bar, or side wall, stones tied in with path stone to maintain footholds.

Uneven gradient

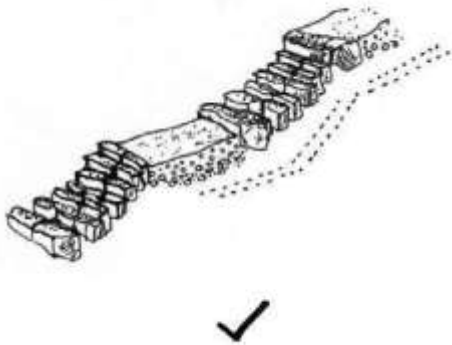

Even gradient over changing terrain

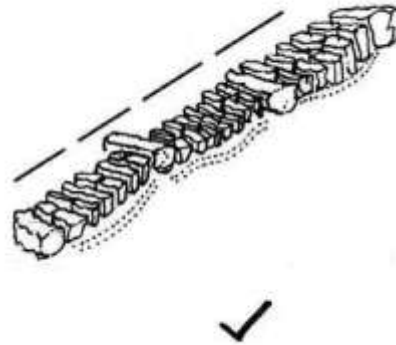

Step 3

Edge finishing

- use sod, boulders and spoil from path tray excavation to landscape path edges, ensuring that edge stone side faces are covered, the line is defined, and the appearance "softened";
- where necessary the edge finishing should raise the path sides to contain path use, particularly to avoid short cutting at corners;
- use excess sod and spoil to re-instate eroded or damaged ground (see Introduction to Restoration Techniques).

Troubleshooting

Key points to watch:

- firmly pack all stonework - this is time consuming but if neglected or not done thoroughly it will result in water damage and stonework collapse; make sure joints overlap for a solid, stable structure;
- provide secure footing - a rough uncomfortable surface will not be used; avoid regular courses of stone that create a formal step;
- match the pitching gradient to the path alignment - avoid steep sections by re-aligning and incorporating curves;
- ensure that the bottom step is flush, or nearly flush with the path leading up to it, ideally the first stone should have a big, deep tread to lead walkers on to the pitching;

Edges too straight
and too many *small stones*

Better edge - bigger stone

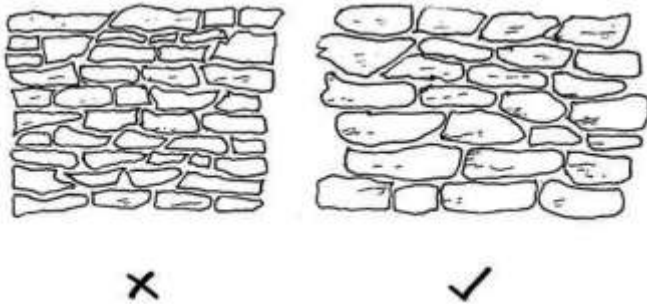

Variations

Stone pitched paths throughout Scotland reflect regional variations, the main influence being the geology.

The type and size of stone results in styles such as:

- Granite (boulder pitching)- large rounded stone - pitching with treads bigger than the average foot size and larger rises;
- Schist - thin slate like stone - pitching with small treads of several stones, but dug in deep;
- Sandstone - smaller blocky stone - pitching using several stone courses to form a "grippy" foothold.

The incorporation of grass seed or small strips of sod, in the packing between stones is suitable on some sites. The vegetation softens the visual impact of the hard pitched path. It can also help to stabilise pitching that may be susceptible to loosening.

Maintenance Tasks

Stone-pitching should require minimal maintenance, other than drainage features and edge work. The main tasks are:

- pack and re-set stonework where there is any movement or visible
- gaps; sod the edges where trampling and erosion has occurred; block
- any shortcuts that develop.

- **ENVIRONMENTAL SENSITIVITIES**

- take care to avoid creating trample lines when collecting large quantities of stone from within reach of the path - vary the route to spread the pressure



- carefully sod over scars left from removed stone, particularly if within sight of the path
 - dispose of excess stone sensitively, or use to create landscaped mounds or to in-fill borrow pits

- **HEALTH AND SAFETY HAZARDS**

- take care to prevent stone falling onto path users or anyone working below when off-loading collected stone, or moving it from a stockpile the work site is often steep, rough and restricted for space -
 - provide alternative routes for the public whenever possible

- **TAKE CARE**

- stone pitching should only be used where there is no alternative available - it is notoriously uncomfortable to walk on for descending walkers
 - incorporate path drainage - surface water, or ice, can make the surface very slippery, assess the site for alternative routes or better alignment
 - if the pitching is lower than the surrounding vegetation, water and snow, will collect on the path. Conversely, pitching which is high and proud does not blend in so well and is more likely to be avoided by walkers

Specification 7

Raised Boardwalk using Recycled Plastic

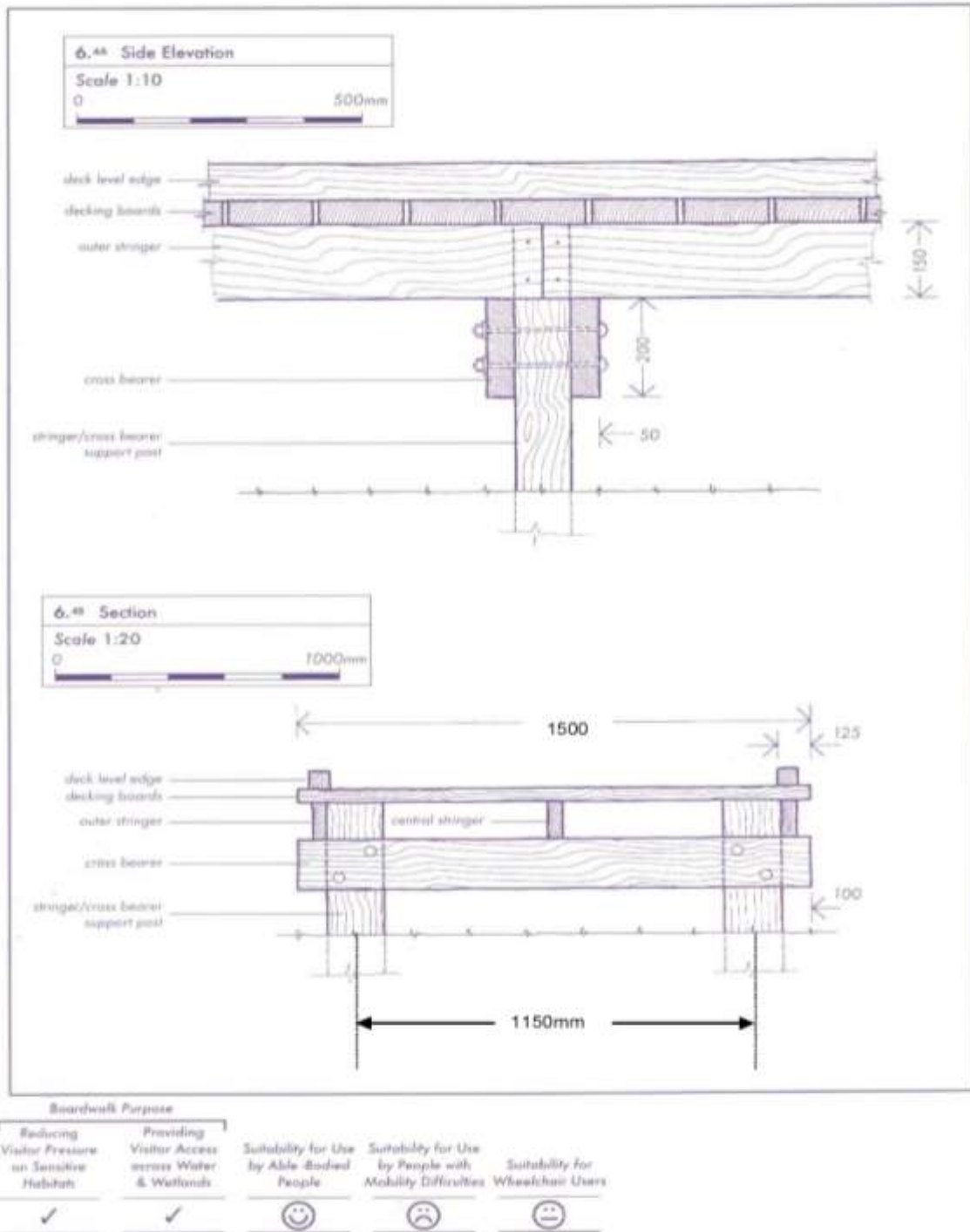

1800mm centre spacing of support posts along the length of the boardwalk

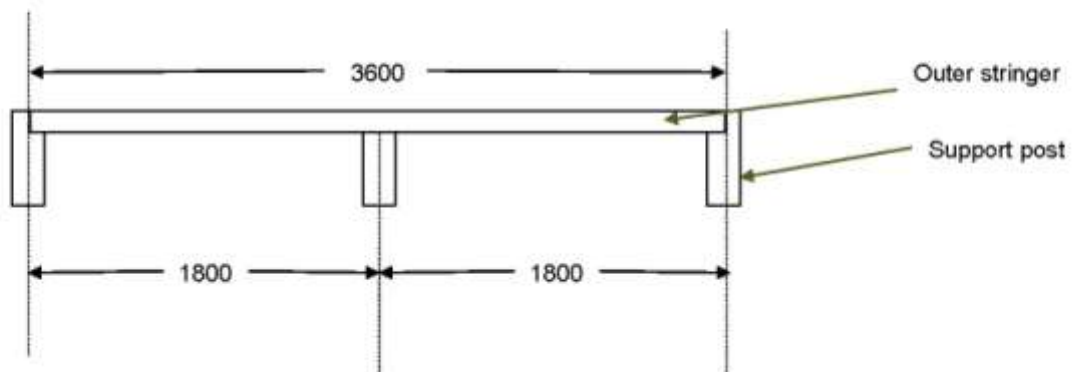

• Notes

A wide design of boardwalk suitable for wetlands, marshes and other situations where the decking needs to be raised above ground level.

For reasons of safety, it should be fitted with deck level edge rails.

This design is suitable for situations where a wider or more robust boardwalk is required. The maximum deck width is 1500mm, providing an accessible clear width of approximately 1200mm between deck level edge rails: this is sufficient to accommodate two-way traffic by wheelchair users.

• Construction and Installation details/sequence

1. Stringer/Cross Bearer Support Posts: 2 no. 200 x 100 x 1200, at 1800 centres (max.) along length of boardwalk, 1150mm between posts for width of boardwalk; sunk to a minimum depth of 600.

2. Cross Bearers: 2 no. 1500 x 200 x 50 per pair of support posts.

Cross bearers fixed to support posts with 4 no. 225 x M12 coach bolts.

3. Central Stringer: 1 no. 3800 x 150 x 50 stringer per boardwalk width. 100 overlap at alternate stringer/cross bearer support posts and nailed to cross bearers.

Central stringer fixed to cross bearers with 100mm galvanised screws

4. Outer Stringers: 2 no. 3600 x 150 x 50 stringers per boardwalk width. Butt jointed at alternate stringer/cross bearer support posts. Nailed to stringer/cross bearer support posts.

Outer stringers fixed to support posts with 100mm galvanised flat headed nails.

5. Decking Boards: 1500 x 150 x 50 with a 10 gap between boards.

Decking boards fixed to stringers with 100mm galvanised annular ring shank flat headed nails (4 no. per board).

6. Deck Level Edge: 75 x 75 rails. Edging should be set 50 in from edge to prevent decking boards from splitting.

Fixed to decking with 100mm M10 galvanised coach screws countersunk.

Specification 8

Light Touch Work – Rationale, Guidance and Method

The use of light touch techniques places great emphasis on creating natural looking features and is a dynamic approach using the minimum amount of work to keep people on the path line. Light touch can be particularly suited to high or wild landscapes, where the ground condition allows, or where the path line is highly visible. It represents ongoing management of a path, rather than a one-off, capital-intensive approach. However, as highlighted above, all upland pathwork should keep construction to a minimum as the basis of design.

Light touch work is just as robust as standard construction and may use distinctive techniques and/or variations in standard construction including:

- de-roughening, which is the process of creating a more desirable walking surface by removing or altering the existing stones in the path surface, rather than digging out a more formal line
- braid blocking to help close down multiple path lines
- sod lined ditches, rather than open
- stone water bars that are less regular than a “typical” bar
- pitching with an informal appearance - uneven rises, large treads contouring around existing bedrock and boulders, utilising these natural features, rather than covering or removing them
- mixed sections with pitching and stretches of path that are barely defined in between
- realigning paths to more robust ground

Because more emphasis is on working with what is already there, the work is more reactive and only the necessary sections of the path (or desire line) will be worked by the contractors. Sites higher up in the mountains with no formal/constructed paths can be protected by using light touch techniques on desire lines. This includes re-aligning the path line onto robust ground by the addition of well-placed blockers, or an occasional step. Line definition includes removal of sod islands, or moving a boulder to create a line of sight. This is often used with de-roughening, to ensure that the user will not deviate from the path line because it has become indistinct. Line definition and de-roughening mainly re-arrange what is already there, with

little need to use additional materials from outwith the path line

Pre-emptive light touch work, for example drainage work, can be highly beneficial in halting damage and holding sites in their present state allowing them to be tackled when resources are available. Without pre-emptive intervention, damage can increase rapidly leading not only to a larger visual scar, greater loss of soils, stone and vegetation but also much higher financial and visual restoration costs.

The light touch approach is also suited to sections of path which are highly visible in the landscape as it allows for a more natural looking line to be used, there is less disturbance to sensitive ground and often less materials are required. All of which can help the route to blend in better than a fully constructed line (whilst it can be possible to hide a full build path, resource requirements will always be high.) It is particularly important that light touch paths are regularly visited to assess any damage, a task best suited to a maintenance team who can assess and repair/add to any work which has failed or not been adequate.

This option is not suited to all sites and a good understanding of what will work where is required. Some sites are too steep, peaty, mobile, damaged, busy, etc. to hold light touch work and will require a more heavily engineered approach. Even when a heavily engineered approach is necessary every effort to camouflage the work should be taken to reduce the visual impact of the line and to keep the line to a minimum width.

Specification 8.1 – Defining A Single Line

A path line may not be immediately obvious to the user if the path material merges well with the surrounding ground, or the path passes through a rough or eroded area. To prevent inadvertent movement off the managed path, further definition will be required in the form of sensitive path edge restoration and landscaping.

Function

Good path management entails encouraging walkers to stay on the managed path. Defining the path line and containing path use are vital parts of this.

The purpose of path definition is to:

- reduce use to a single line and prevent it spreading across a wider area

- minimise the impact of the path in the upland landscape
- revegetate and stabilise weak or poorly vegetated path edges

Bill of Quantities (example)

Define one path line. Remove any loose large stone and obstructive boulders or sod islands to the path margins. Set in boulders and transplant sods as informal path edges to define the path line and width.

As well as being an essential element of pathwork, it can be a minimal impact technique to define a path line without the use of surfacing materials. This is suitable on stable stony or

eroded ground, where path use has spread over a wide area. The aim is to provide a more comfortable walking surface, within a clearly defined width.

Methods

Path definition requires great care. An aim of upland pathwork is to minimise its impact in the landscape and path definition will conflict with this if it is not sensitively undertaken.

Defined path sides should merge naturally into adjoining ground. The methods used must be appropriate to the character of the path, its surface and the surrounding landscape.

Methods include:

- placing sod the path edges
- shaping or restoring banking at path edges
- placement of stabilising stone
- movement of loose stones, boulders and sod islands

Materials

The types of materials available are usually quite limited, and include:

- Boulders and stone
- Sods

These materials and the general principles for their use are detailed in materials and use.

Procedure

Natural Surfaces

A single path line should be defined wherever problems are encountered with walkers following a variety of lines across a wide area of rough ground. This involves the careful "sorting" of the natural, or eroded, surface material.

All rough loose stones and boulders are removed from the preferred path alignment, unless they provide good and solid footholds. Small stone is scattered in the alternative lines. Larger stone and boulders are then set into the ground to define an informal path edge. Any islands of sod remaining are carefully transplanted either at the path edge or in the alternative lines to provide a natural appearance, appropriate to the surrounding area.

The alternative path lines may need additional blocking (see containing path use).

Aggregate Paths

Placing sod of the aggregate path edge may have been undertaken as part of the construction, particularly where the path tray sides were unstable, or geotextile used.

Additional definition, with sods and boulders if appropriate, may be needed at changes in alignment, and to help vary the path width. Placing sod may also be required to slightly raise the path edges and prevent the aggregate surface from spreading or eroding with use. The use of sods will soften the edges and encourage vegetation to grow into the aggregate.

Sods should be laid right up to the path edge, maintaining a variable path width. Care should be taken to avoid creating straight lines. Incorporating small boulders or large stones can help to give a natural look to regular placing sod, as long as they are randomly placed, and not in a uniform line along the path edge.

Pitched Paths

Pitched paths are often constructed through wide rough and eroded areas. The placement of boulders and sod, particularly at changes in width and alignment will help to define the edges.

The path surface should not be higher than the adjoining ground and the placing sod angled to form a bank that is not suitable for walking on. The sod should be butted tightly into the pitched stone, to encourage it to grow over and soften the edges.

Under-cutting

Where a traversing path is benched into the slope the uphill bank may become under-cut by path use, weathering, or sheep sheltering. This can lead to overhanging sod that is liable to collapse onto the path. A path that has eroded to form a stable mineral surface can also leave over-hangs, on both sides.

In these cases it is necessary to reshape and stabilise the path sides. This can be done by rebuilding the eroded bank with boulders, and sods. Alternatively, if no material is available, the sod may be carefully lifted, the soil underneath reshaped down to the path edge, with the overhanging sod transplanted over it. In both methods the banking should be angled back, so that undermining is less likely to re-occur.

Drainage Features

Wherever drains extend outside the path width the path edge should be defined with large sods or stone. This helps to soften the appearance of a stone drain and stabilise the path edge where it joins the drain construction. Care is needed in placing the sod to avoid channelling path use into the drain rather than onto the path.

Troubleshooting

Key points to watch:

- make sure that boulders or stones are secure and will not move onto the path line
- ensure that edge definition channels walkers onto and not off the path
- avoid regular and even placement of sod and boulders - position randomly

Maintenance Tasks

The following maintenance may be required:

- replace any dead, worn or displaced sods
- re-set, or replace any loose or dislodged boulder

8.2 Containing Path Use

People moving off the path line can cause damage and erosion of fragile revegetating areas. It is essential to prevent this with careful landscaping and placement of 'natural' obstructions, as part of the site restoration.

Function

Incorporating "blocking" features, or obstacles, in the site restoration serves to channel and contain use on the path and discourage walkers from leaving it. Before considering preventative work it is necessary to identify why and where users will be tempted to move off the path line. This may include:

- poorly constructed or rough path surface
- steep or difficult sections of path
- easier walking ground adjacent to a hardened path
- short zigzags on a slope where walkers can descend an easy fall line
- old path lines appearing as alternative or more direct routes
- poorly positioned drainage features channelling use off the path
- steep path crossfalls "pushing" use off the path edge
- short-cuts or desire lines to a particular destination

Bill of Quantities (example)

Use large boulders and sods with landscaped mounds to prevent use of path sides, alternative paths or desire lines. Obstacles and mounds must be large enough to contain path use but appear natural and blend with the surrounding area.

Methods

The following methods developed to channel and contain path use can be used together or individually, depending on the nature of the site and the problem.

- strategic positioning of large blocking boulders
- sod and spoil bunds, mounds and bankings
- sod and stone placement over alternative paths
- ground roughening of open path sides

The appropriate choice will depend to a large extent on the materials available.

Materials

Any of the following can be used to contain path use:

- Boulders
- Sods
- Spoil
- Mixed size stones

These materials and the general principles for using them are detailed in Materials and Use.

Positioning

Whichever method is used to prevent movement off the path, it should not be perceived by users as a deliberately placed obstacle. Rather than being a physical barrier the obstacles should create an impression of difficult ground. To be effective these need to be carefully positioned where problems may occur. The most common places are at:

- changes in the type or condition of path surface
- points of access off the path onto easier ground
- path corners or changes in alignment
- changes in gradient, particularly the top of steep downhill sections
- points where braids or old paths leave, or are obvious from, the path line
- drainage features on corners or bends, particularly waterbars
- lower path sides on traversing paths
- the point where destinations become obvious or visible e.g. car parks, viewpoints, landscape features

For strategic positioning it should be remembered that the path user's visual assessment of a better or alternative route will be different when ascending and descending.

When blocking ascending off-path use, the obstacle needs to be at the path edge, as the walker's view will be limited to the slope immediately above.

A descending walker will be looking further ahead, and over a wider area. More than one feature will be required, positioned randomly, but to obstruct the view of an alternative line and to give the appearance of rough ground.

On zigzag paths the best position is immediately below the lower path edge particularly at the bends.

Procedure

Blocking Boulders

Large boulders should be used, at the point where walkers may be tempted off the path by an apparently better route. The best positioned blocking boulders will not be obvious to path users. Sods transplanted around them will help to achieve this.

On alternative paths or wide path sides more than one boulder may be required, and care with positioning is needed. Blocking boulders, and their placement, must mimic and look as natural as any others in the surrounding landscape.

Bunds, Mounds and Bankings

Along with occasional boulders, these are the ideal method of containing path use, so long as their appearance blends with surrounding area. They may be the only option available in situations where boulders are in short supply or do not fit the surrounding area. Using spoil and sods they can create longer obstacles, either along the path edge or at an angle to the path, and, as low mounds, across alternative paths or braids. As well as blocking off-path use they encourage or divert use onto a particular alignment, particularly on zigzag paths.

Carefully positioned raised bunds or banks along the path edge, are helpful in preventing movement off the path onto revegetating sides, but great care needs to be taken to create banks that fit within the landscape. They also serve to reduce the visual impact of a hard path edge or the path alignment.

Where there is no spoil or sod available, mounds and hollows can be carefully created. Sod is removed over an area, and a hollow dug; the spoil is used to create a mound; and both the hollow and mound re-sodded. This is particularly useful to prevent use of easier, softer ground adjacent to a hard path.

Mounds used as obstacles must be substantial enough for the purpose, and rough enough to deter use over them. However, care is needed to avoid creating unnaturally high features.

As with boulders, the emphasis is on their natural appearance, avoiding uniform shapes or positioning. Where used for banking alongside the path edge, care is needed to avoid long unnatural looking mounds of regular width.

Placing sod

Large sods can be used, with boulders if appropriate, at the path edges to prevent movement off the path, and to disguise and block the line of braids and desire lines. The aim is to 'roughen' the appearance and care should be taken not to create a better walking option than the path.

Ground roughening

This method is suitable on wide open areas adjacent to the path, where large boulders or sodded mounds would not be appropriate. The aim is to roughen the ground enough for it to appear unattractive to walk on. On eroded ground this can be achieved with mixed size, weathered stone scatter over the surface. Small, low mounds and hollows may also be appropriate. These can also be used effectively to create an uneven grassed area. Mixed height placing sod, combined with weathered medium size stone can also achieve the desired effect. Particular care is needed with this method to avoid a contrived unnatural patchwork of material.

Troubleshooting

Key points to watch:

- correct positioning of the feature - further erosion will occur if walkers continue to deviate from the path
- avoid periods of dry weather when placing sod

Maintenance Tasks

The following maintenance may be required:

- replace worn or dead sods
- reset loose boulders or stone
- move, or extend features to effective positions